



WWW.JEVINSTRUMENTS.COM



Agilent TwisTorr 74 FS



The new generation Turbo Pump with Agilent Floating Suspension

The Agilent TwisTorr 74 FS turbomolecular high-vacuum pump combines TwisTorr drag stage technology and Agilent Floating Suspension to provide high performance, reliability, and economy in such applications as academia and research, and others that require pumps for long-term operation.

TwisTorr drag stages create high compression ratios for light gases such as hydrogen and helium to deliver high throughput and high tolerance of foreline pressure, thereby permitting the use of smaller and more economical backing pumps. This technology results in a compact rotor design that is energy-efficient and maintains a low operating temperature.

The Agilent Floating Suspension system reduces noise and vibration, and ensures optimal bearing operating conditions to extend operating life, minimize system downtime, and assure stability over time.

The unique bearing and dry lubrication in the TwisTorr 74 FS eliminate oil and maintenance, and permit operation of the pump in any orientation. Available with onboard or rack controllers.

Technical Specifications

Technical Specifications				
Pumping speed	KF40	CFF 2.75"	ISO 63	CFF 4.5"
N ₂	44 L/s	50 L/s	60 L/s	60 L/s
He	33 L/s	40 L/s	54 L/s	54 L/s
H ₂	28 L/s	31 L/s	42 L/s	42 L/s
Ar	40 L/s	51 L/s	59 L/s	59 L/s
Max Gas Throughput (*)	Air Cooling (35°C ambient temperature)		Water Cooling (25°C water temp. / 35°C ambient temp.)	
N ₂	130 SCCM		130 SCCM	
Ar	80 SCCM		80 SCCM	
(*) Backing pump 5 m ³ /h				
Compression ratio and foreline tolerance (**)				
N ₂	1.0 x 10 ⁹		>12 mbar	
He	2.0 x 10 ⁵		>10 mbar	
H ₂	1.0 x 10 ⁴		>4 mbar	
Ar	> 1.0 x 10 ⁹		>14 mbar	
(**) Foreline Tolerance defined as the pressure at which the turbopump still produces a compression of 100, estimated in water cooling mode				
Base pressure with recomm. forepump	< 5 x 10 ⁻¹⁰ mbar (< 3.75 x 10 ⁻¹⁰ Torr)			
Inlet flange	KF 40, ISO 63, CFF 4.5", CFF 2.75"			
Foreline flange	KF16 NW			
Rotational speed	70000 rpm (1167 Hz driving frequency)			
Start-up time	< 2 minutes			

Technical Specifications		
Recommended forepump	Agilent DS 40M / DS 102 Rotary Vane Pumps Agilent IDP-3/IDP-7 Dry Scroll Pumps	
Operating position	Any	
Oper. ambient temp.	+5 °C to +35 °C	
Rel. humidity of air	0 - 90 % (not condensing)	
Bakeout temperature	max 80 °C for ISO (120 °C for CFF) at inlet flange	
Lubricant	Permanent lubrication	
Cooling requirements		
Air cooling	Forced air Air flow temperature +5° C to +35 °C	
Water cooling	Water temperature from +15°C to +25°C Water flow min. 65 L/h	
Noise Pressure level (at 1 mt at full speed)	40 dB(A)	
Storage temp.	-40 °C to +70 °C	
Max altitude	3000 m	
Weight kg (lbs)	ISO 63	2.05 (4.50)
	CFF 4.5"	3.50 (7.70)
	CFF 2.75"	3.34 (7.35)
	KF 40	2.37 (5.22)

Conformity to norms	
CE, C-CSA-US, RoHS compliant as per 2011/65/UE	

Outline Drawing

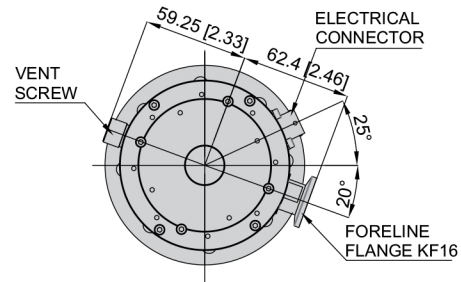
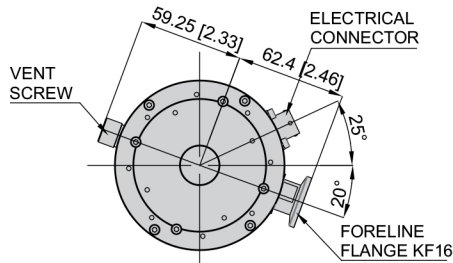

JEVI
VACUUM
INSTRUMENTS

WWW.JEVINSTRUMENTS.COM



Dimensions: millimeters [inches]

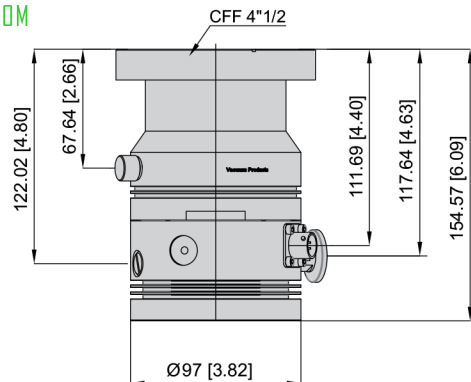
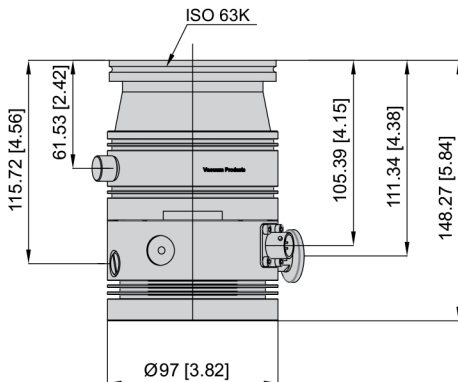

3D Drawings available for download on Agilent.com



Ordering Information

Pumps	Part Numbers
TwisTorr 74 FS ISO 63	X3502-64170
TwisTorr 74 FS KF 40	X3502-64171
TwisTorr 74 FS CFF 4.5"	X3502-64172
TwisTorr 74 FS CFF 2.75"	X3502-64173
Controllers	
TwisTorr 74 FS AG rack controller RS232/485	X3508-64301
TwisTorr 74 FS AG rack controller Profibus	X3508-64022
TwisTorr 74 FS onboard controller 110/220V	X3509-64030
TwisTorr 74 FS onboard controller 24V	X3509-64021
TwisTorr 74 FS PCB controller	X3510-64050
Cables	
Mains cable NEMA plug 3 m long	9699958
Mains cable EU plug 3 m long	9699957
Serial cable and A-PLUS software	9699883
PCB cable	9699869
Pump extension cables	9699942 (3 m) 9699942M007 (5 m) 9699942M006 (10 m) 9699942M005 (15 m) 9699942M004 (20 m)
Inlet Screen	
Inlet screen ISO 63	X3502-68001
Inlet screen CFF 4.5"	X3502-68000
Inlet screen, KF 40	9699309
Inlet screen CFF 2.75"	9699328
Cooling	
Metal water cooling kit	X3502-68002
Plastic water cooling kit	X3502-68003
Air cooling kit (0,5 m cable)	9699290
Air cooling kit extension cable (5 m)	9699940

Vibration isolator	
Vibration isolator ISO 63	9699375
Vibration isolator CFF 4.5"	9699376
Venting	
Vent Valve N.O. 0.5 mm orifice (0.5 m cable)	9699844
Vent Valve extension cables	9699941 (5 m) 9699941M003 (10 m) 9699941M001 (15 m) 9699941M005 (20 m)
Vent Screw M5	X3502-68005
Vent Adapter kit M5-M8	X1699-64039
Purge	
Purge Screw	X3502-68004
Purge valve 10 SCCM NW16KF - M12	9699239
Purge valve 10 SCCM ¼ Swagelok - M12	9699240
Purge valve 20 SCCM NW16KF - M12	9699241
Purge valve 20 SCCM ¼ Swagelok - M12	9699242
Purge valve 10 SCCM ¼ Swagelok - ¼ Swagelok	9699232
Purge valve 20 SCCM ¼ Swagelok - ¼ Swagelok	9699236
Mounting	
Onboard controller side mounting bracket	X3502-68006
CFF4.5 Mounting kit	X3502-68007
Metric screws kit	X3502-68008
American screws kit	X3502-68009
Active Gauges	
FRG 700 Full Range Gauge PVG 500 Pirani Vacuum Gauge PCG 750 Pirani Capacitance Gauge CDG-500 Capacitance Diaphragm Gauge	Ask Agilent for details

Compression Ratio

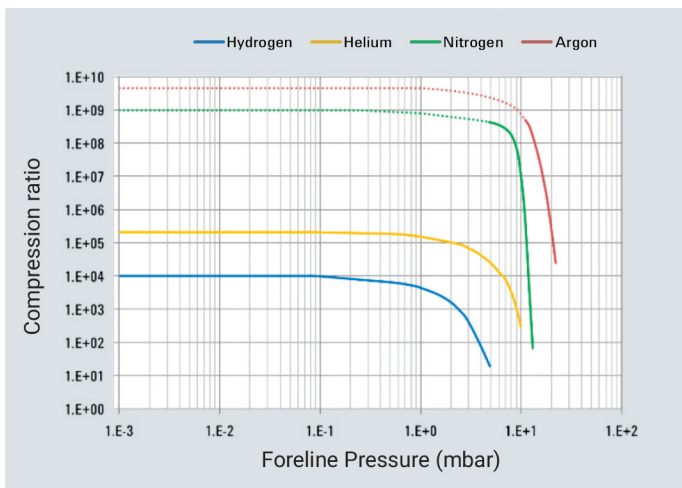

Pumping Speed

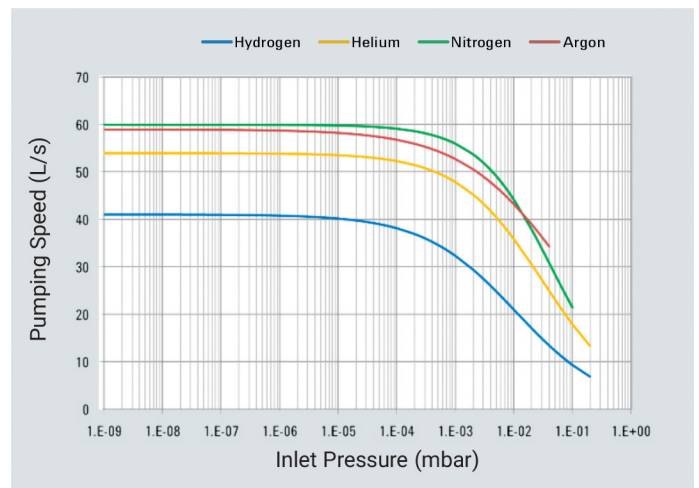

www.agilent.com/chem/twistorrfsfamily

United States

Agilent Technologies
121 Hartwell Avenue, Lexington MA 02421, USA
Tel: +1 781 861 7200
Toll free: +1 800 882 7426
vpl-customer@agilent.com

Europe and other countries

Agilent Technologies Italia SpA
via F.lli Varian 54, 10040 Leini, (Torino), Italy
Tel: +39 011 9979 111
Toll free: 00 800 234 234 00
vpt-customer@agilent.com

This information is subject to change without notice.

© Agilent Technologies, Inc. 2020
Published in the USA, July 1st, 2020
5994-0536EN

JEVI
VACUUM
INSTRUMENTS

WWW.JEVINSTRUMENTS.COM

