

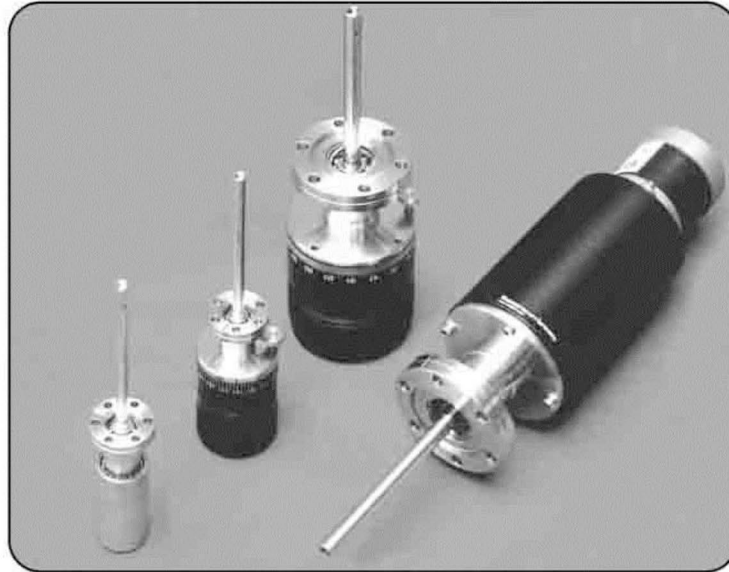

# Operating and Maintenance Handbook

## Magnetic Rotary Drives



Copyright Notice 2002 by VACGEN. All rights reserved. Information contained in this handbook is subject to change without notice and does not represent a commitment on the part of VACGEN. No part of this document may be copied or distributed, transmitted, transcribed, stored in a retrieval

REVISION	DATE	COMMENTS	INITIALS
1	April 2004	Original release	MJD
2	Aug 2015	VACGEN brand	AJL

system or translated into any human or computer language, in any form or by any means, electronic, mechanical, magnetic, optical, manual or otherwise or disclosed to third parties without the express written permission of VACGEN, Maunsell Road, Castleham Industrial Estate, St, Leonards on Sea, East Sussex, TN38 9NN, UK

## WARRANTY



1. Subject to fair wear and tear and the due, observance of any installation user, storage, operating or maintenance instructions the Seller undertakes to replace or, at its option repair free of charge to the purchaser, any goods which the purchaser can establish are defective by reason of defective workmanship or materials which are returned to the Seller, carriage paid, within 12 months of the date of dispatch by the Seller. In the event, however, that the Seller supplies spare parts either direct, or that are fitted or installed or replaced by the Sellers' service center such spare parts will be subject to a warranty period of six months only.
2. The Purchaser cannot return any product for warranty repair without the prior approval of VACGEN and the issue of a Goods Return Number (GRN). This shall be obtained by contacting the service center at VACGEN. All returned products must be accompanied by a completed Declaration of Contamination form. Customers must, in the first instance, contact the local selling agent.
3. We reserve the right to decline to service equipment, we consider is in any way hazardous until a clearance or safety certificate, in a form satisfactory to VACGEN, has been completed and returned by the customer.

## REPAIR

The following additional terms and conditions apply in the event that the customer elects to use the services of VACGEN workshop on a chargeable basis.

1. At its own cost the customer shall dispatch the equipment to the workshop, carriage paid, suitably packaged, protected and insured, bearing, a Goods Return Number (GRN) and a completed Declaration of Contamination certificate obtained from VACGEN in advance of shipment.
2. During the period that the equipment is on VACGEN premises, VACGEN will insure the equipment against all risks.
3. Vacuum Generator will provide an acknowledgement of the receipt together with an estimate of the repair charges. Such estimates are carried out on a visual basis and are therefore intended as a guide only. Formal fixed price repair quotations are available and involve the disassembly of the equipment to determine the full extent of the work necessary to restore the equipment to an acceptable standard. In the event that the customer chooses not to proceed with the repair VACGEN will make a charge to cover this examination effort.

### Note:

The above are extracts from VACGEN Conditions of sale. Complete copies can be obtained from: VACGEN, Maunsell Road, Castleham Industrial Estate St. Leonards on Sea, East Sussex, TN38 9NN, United Kingdom.

## 1. INTRODUCTION



### 1.1 HEALTH AND SAFETY INFORMATION

This equipment is a component for use with vacuum systems. Whilst every effort has been made to eliminate hazards, its safe use is also dependant on the system to which it will be connected.

The owner of the equipment must ensure that all users are aware of the Health and Safety information contained in this handbook. If the equipment is sold or passed to another owner, this handbook must be included with the equipment. If in doubt contact VACGEN.

**Warning:** This equipment must be installed by qualified personnel.

**Warning:** It is the responsibility of the user to consider the safety requirements of hazardous materials used with this equipment and the consequence of any leakage, however caused. Consider possible reactions with materials of construction. Any equipment returned to VACGEN must have the correct Declaration of Contamination securely fastened to the outside of the packaging.

**Warning:** Harmful gases may be evolved if this equipment is heated to temperatures above the maximum specified bakeout temperature.

**Warning:** Lubricants used in this assembly may cause irritation to sensitive skin. Wear protective clothing.

**Warning:** Safe disposal of the equipment is the responsibility of the user.

**Warning:** It is the responsibility of the user to fit emergency stops to automated equipment.

**Warning:** Keep clear of moving pans.

**Warning:** Do not use this equipment with positive internal pressure above the specified maximum.

## 1.2 PRODUCT OVERVIEW



**MRD6, MRD91:** (Figures 1 and 2) These high precision drives for general applications have minimal backlash and axial play. A graduated handwheel and position lock are fitted as standard. The MRD91 and MRD6 drives can be motorised and also have an O-ring drive groove machined into the handwheel.

**MRD93:** (Figure 3) This is a low cost version of the MRD91. It has the same internal mechanism as the MRD91 but does not have a graduated handwheel. It has a simple rotation lock and cannot be motorized. An O-ring drive groove is not provided.

## 1.3 Construction

The vacuum envelope of all MRD series drives is machined from a single piece of 316 grade stainless steel. There are no seals, welds or joints in the vacuum envelope. All parts within the vacuum envelope (with the exception of the magnets) are either stainless steel or 6082 grade aluminium alloy. All moving parts are supported with ball bearing. Internal bearings may be dry-film lubricated or, for extended service life applications, lubricated with vacuum compatible lubricant. External bearings are lubricated with high temperature lubricant. In all cases minimal quantities of lubricant are applied.

## 1.4 Specification

	MRD6	MRD91	MRD93
Rotation (continuous)	360°	360°	360°
Maximum Speed	500rpm	1000rpm	1000rpm
Breakaway Torque	3Nm	0.5Nm	0.5Nm
Shaft Thrust	40N	10N	10N
Shaft Concentricity	0.1mm	0.1mm	0.1mm

**Table One - Drive Specification**

### Data

Construction: One-piece machined stainless steel vacuum envelope  
 Pressure Range: Atmospheric pressure to less than  $10^{-11}$  mbar  
 Bakeout temperature: Extended Life Range - 200°C without dismantling  
 UHV Range - 250°C without dismantling

*Note: Motor must be de-mounted for bakeout.*

Mounting flange. MRD6 - DN35CF (70mm OD)  
 MRD91/93 - DN16CF (34mm OD)

Orientation: Any

**Other Facilities-**  
 Rotational Lock: Standard on all models  
 Inline Motor Kit: Available for MRD91 and MRD6  
 O-ring Drive Groove. Standard on MRD6 and MRD91

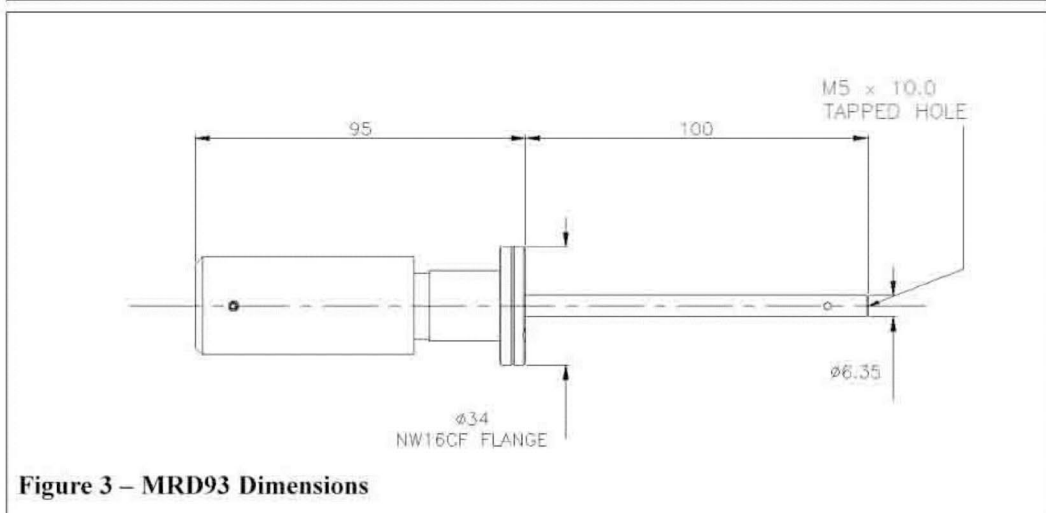
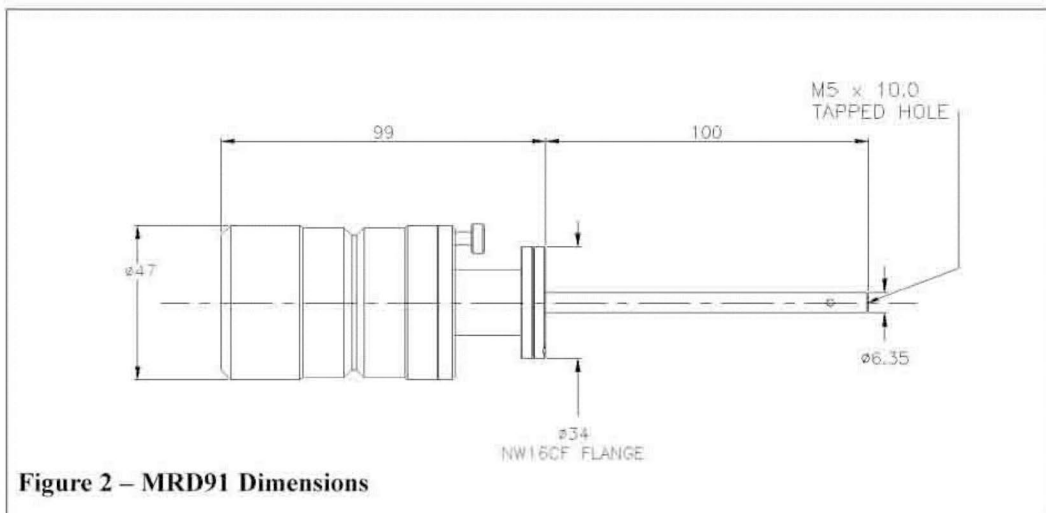
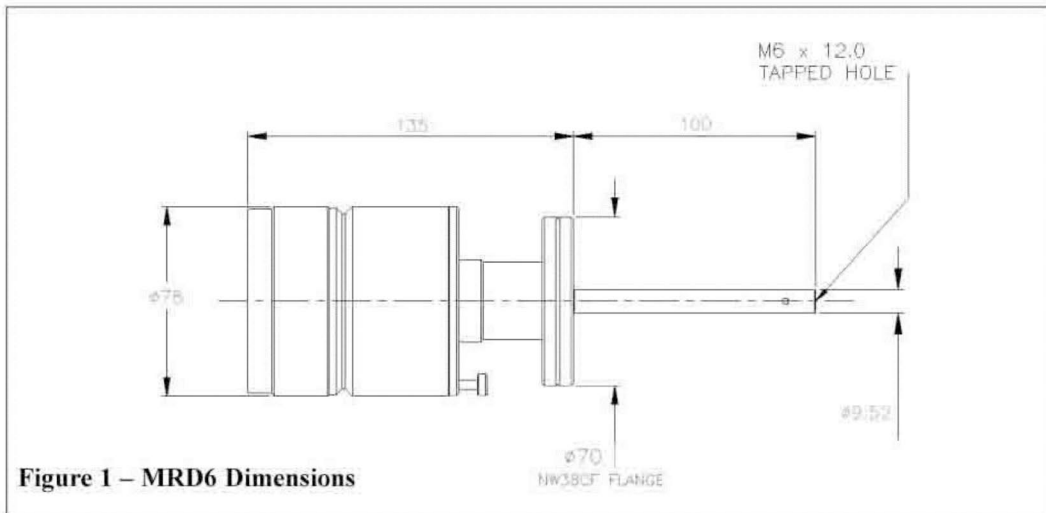

## 2. INSTALLATION

### 2.1 Mounting the Drive to the system

These drives are fitted with standard ConFlat flanges and require a similar mating flange on the system. When bolting up, use an appropriate gasket for the application (refer. to Section 5: Spares and Accessories for the available gasket options). It is advisable to use a thread lubricant on the bolts and to tighten the bolts gradually and evenly in a diagonal pattern to minimise the risk of leaks.



**Warning:** This equipment must be installed by qualified personnel.

**Warning:** It is the responsibility of the user to consider the safety requirements of hazardous materials used with this equipment and the consequence of any leakage, however caused. Consider possible reactions with materials of construction. Any equipment returned to VACGEN must have the correct Declaration of Contamination securely fastened to the outside of the packaging.

**Warning:** Lubricants used in this assembly may cause irritation to sensitive skin. Wear protective clothing.

**Warning:** Do not use this equipment with positive internal pressure above the specified maximum.

## 2.2 Rotary Drive Motor Kits

### 2.2.1 MRD6 & MRD91 primary axis motor kit

#### Description:

The Primary Axis Motorisation Kit (See page 14 for a full list of motor kits) can be easily retro-fitted to the MRD6 and MRD91 drives. The motor is an 8 lead, 4 phase hybrid stepper motor. VACGEN reference. 23HS108E. A full description of the motor and connections is given in Appendix A. The motor can be driven by any of the VACGEN stepper motor control units type ZSAC or ZMAC.

Other controller types can be used, but the performance may be affected. VACGEN cannot advise on alternative controller selection or be held responsible for loss of performance.

The motor unit should be removed for bakeout. For high precision repeatability, always approach measured positions from the same direction of rotation. Operating temperature range is  $-20^{\circ}\text{C} + 40^{\circ}\text{C}$ .

**Warning:** To comply with EU directives, emergency stops must be fitted to locations that safeguard the user at all times.

#### Fitting the primary axis motor kits to the MRD6 or MRD91 drive:

Numbers in ( ) refer to the items indicated in figure 4 (page 11)

- a. Remove the 4 off caphead screws (1) from the handwheel (2). Remove the handwheel.
- b. Remove the rotation lock screw & spring (3).
- c. Attach the drive adapter (4) using the 4 off caphead screws provided (5).
- d. Fit one half of the drive coupling (6) to the drive adapter. Secure with the grub-screw.
- e. Fit the other half of the drive coupling (7) to the motor shaft. Do not tighten the grub-screw.
- f. Fit the motor to the motor sleeve (9) using the 4 off caphead screws provided (10).
- g. Slide the motor sleeve 1 motor assembly over the drive body and secure using the 4 off caphead screws provided (11).
- h. Ensure that the two halves of the drive coupling have fully engaged and that the drive rotates freely. Tighten the drive coupling grub screw through the access hole in the motor sleeve.
- i. Finally check that the drive rotates freely. The drive is now ready for use.

**Warning:** Keep clear of moving parts.

## 2.2.2 MRD6 and MRD91 motor options

### Description



The MRD6 and MRD91 rotary motion drives can be supplied with either a direct acting stepper motor (MRD6M or MRD91M), or a brushless DC motor (MRD6D or MRD91D).

The stepper motors are 8 lead, 4 phase hybrid stepper motors with a standard 23 frame size. A full description of the motors and connections is given in Appendix A. The motors can be driven by any of the VACGEN stepper motor control units type ZSAC or ZMAC.

The brushless DC motors are supplied complete with local manual controls and a universal 24V power supply. They do not require a separate mains transformer or motion controller for simple, open-loop operation.

Other controller types can be used, but the performance will be affected. VACGEN cannot advise on alternative controller selection or be held responsible for loss of performance.

For bakeout, the motor unit must be removed.

### Performance with VACGEN controllers

MRD6	Direct Motor (M)	DC Motor (D)
Gear Reduction	1:1	5:1
Motor Connection	Coils in parallel	Brushless
Maximum Speed	300rpm	300rpm
Movement per halfstep	0.9°	-
Torque*	43 Ncm @ 500rpm	38 Ncm @ 300rpm
	0.5 Ncm @ 10rpm	0.3 Ncm @ 300rpm

MRD91	Direct Motor (M)	DC Motor (D)
Gear Reduction	1:1	5:1
Motor Connection	Coils in parallel	Brushless
Maximum Speed	500rpm	300rpm
Movement per halfstep	0.9°	-
Torque*	28 Ncm @ 500rpm	24 Ncm @ 300rpm
	0.5 Ncm @ 10rpm	0.3 Ncm @ 300rpm

**Table 2 - Motorised Drive Specifications, MRD6 and MRD91**

\* Other torque-speed performance may be possible by series motor connection, or by fitting alternative motors.



### 3. OPERATION

#### 3.1 MRD91, MRD93 and MRD6

##### 3.1.1 Primary axis rotation

A rotation locking screw allows the rotary motion to be locked in any desired position. The MRD91 and MRD6 are fitted with a knurled thumbwheel rotation lock. The MRD93 utilises an M3 grub screw and therefore requires a hexagon wrench for rotation lock operation

**Warning:** Always release the locking screw before rotation.

##### 3.1.2 Motorised Drives

The operation of motorised drives will depend largely on the motor controller used. Please consult the appropriate documentation.

**Warning.** Be aware of the danger of trapping hair or fingers in the equipment. Keep clear of moving parts. Emergency stops should be fitted by the installer of this equipment.

**Warning.** Where stepper motors are fitted, the motor connectors must not be disconnected unless the power to the drive has first been switched off. Allow a few seconds for the circuit to discharge.

**Warning:** Microswitches are for use as over travel stops only. Do not use as position stops or indicators. Depending on the controller used, the motor will attempt to stop immediately a limit switch is activated, and it is likely that steps will be lost due to motor overrun.

For accurate positioning, allow all motors to reach a stable temperature before starting work and arrange the drive so that the direction of any motion should be consistent to avoid backlash errors.

#### 3.2 Bakeout

##### 3.2.1 Bakeout limitations

The bakeout limits of all drives are stated in Specifications, section 1.4. Vacuum Generators cannot accept any responsibility for any damage to equipment arising from failure to observe the following notes:

- a. Heat by convection only.
- b. The sensing element of the VACGENcouple controlling the heaters must be suspended in air near to the rotary drive and approximately 50mm below the uppermost portion of the drive.
- c. Under NO circumstances should the sensing element be attached directly to (i.e. be in thermal contact with) the rotary drive or any other part of the vacuum system.

**Warning:** Surfaces on this equipment will remain hot for long periods after bakeout. Do not force cool. Use gloves when handling.



### 3.2.2 Baking to 250°C/200°C



**Note:** The rare earth magnets fitted to magnetic rotary drives must not be exposed to temperatures above the maximum specified for the drive. Exceeding the recommended bakeout temperature can seriously affect the performance of the drive.

- a. Where fitted, release the rotation lock before baking the device.
- b. Where fitted, remove all motors, microswitches and wiring from the bakeout zone. Specific instructions on removal of each motor unit are included in the following sections:

#### Bakeout procedure for the Primary Axis motor kit

The motor and all wiring must be removed from the bakeout zone for bakeout as follows:  
Refer to figure 4 (page 11).

- a. Remove the 4 off caphead screws securing the motor sleeve 1 motor assembly.  
Note: ensure that the drive is adequately supported during this operation.
- b. Carefully remove the sleeve 1 motor assembly from the drive. The drive is now ready to be baked.
- c. After bakeout, replace the sleeve 1 motor assembly onto the drive, ensuring that it is properly located on the stop ring locating shoulder.
- d. Turn the sleeve 1 motor assembly to line up the screw holes & replace the 4 off M4 screws. Tighten to 5Nm torque.
- e. Check for correct functioning of the drive.

## 4. MAINTENANCE

### 4.1 Routine inspection schedule

The following inspections and procedures should be performed at 6 monthly intervals, or after 150 to 200 hours of accumulated bakeout, or when any movement becomes less smooth than normal. Disconnect any power supplies and check the fixing screws of all drives, most of which should be secure, i.e. neither slack nor excessively tight. This is particularly important for motorised drives.

### 4.2 Lubrication

#### 4.2.1 Lubrication overview

It is necessary to renew the lubricants used on the moving parts that are external to the vacuum envelope after approximately 400 to 500 hours accumulated bakeout, or when any of the motions appear to require more effort to operate than previously. This period may vary depending on the bakeout temperature and amount of normal use. The lubricant should cover the bearing surfaces and should be free of wear debris, which is normally seen as a blackening of the lubricant.

Note that high temperature grease, used to externally lubricate all drives, discolours with time, becoming brown in colour. This is accelerated where regular bakeouts are applied to the equipment, but this does not affect the performance of the lubricant.

The standard VACGEN lubrication kit (order code ZLUBEK) contains all necessary lubricants.

**Warning:** Lubricants used in this product may cause irritation to sensitive skin. Wear protective clothing.

**Warning:** Keep clear of moving parts on motorised units - Switch off the electrical supply before starting maintenance.

#### 4.2.2 MRD91 & MRD6 primary axis lubrication



The bearings within the vacuum enclosure are treated with either a solid film lubricant (standard drives) or a UHV compatible lubricant (extended-life drives). The vacuum-side bearings are sealed for life and require no maintenance. The bearings that are external to the vacuum enclosure can be lubricated in-situ as follows:

Numbers in ( ) refer to the items indicated in figure 5 (page 12).

- a. Remove the drive from the vacuum system.
- b. Remove the four caphead screws retaining the handwheel (2). Remove the handwheel
- c. Remove the retaining circlip (3) using suitable circlip pliers. Remove the outer thimble assembly complete with the bearing (4) & the preload washer (5).

**Warning:** Always wear eye protection when installing/ removing circlips or spiral retaining rings.

- d. Carefully remove the spiral retaining clip (6) from the thimble assembly. Remove the bearing (7). Take care not to lose the preload spring (8)
- e. Use solvent to wash out old lubricants from the bearings.

**Warning:** If ultrasonic cleaning is needed, limit the ultrasonic time to 3 or 4 seconds, otherwise permanent bearing damage may occur.

- f. Ensure that both bearings are dry and free of solvents.
- g. Lubricate both bearings with eight drops of high temperature lubricating fluid in each bearing. Rotate the inner races several turns to distribute the fluid.
- h. Replace the bearing (7) in the thimble assembly on top of the preload washer (8).
- i. Refit the spiral retaining ring (6), ensuring it is fully seated in its groove
- j. Replace the outer thimble assembly on the drive, followed by the bearing (4) with its preload washer (5). Replace the retaining circlip (3). Ensure that the thimble rotates freely.
- k. Replace the handwheel & secure with the 4 off M4 screws (1).
1. Clean off unwanted lubrication marks with solvent.

#### 4.2.3 MRD93 primary axis lubrication

The bearings within the vacuum enclosure are treated with either a solid film lubricant (standard drives) or a UHV compatible lubricant (extended-life drives). The vacuum-side bearings are sealed for life and require no maintenance. The bearings that are external to the vacuum enclosure can be lubricated in-situ as follows:

Numbers in ( ) refer to the items indicated in figure 4 page 13.

- a. Remove the drive from the vacuum system.
- b. Remove the rotation locking grub screw (3).
- c. Remove the retaining circlip (1) using suitable circlip pliers. Remove the outer thimble assembly together with bearing (2).

**Warning:** Always wear eye protection when installing / removing circlips.

- d. Carefully remove the spiral retaining clip (4) from the thimble assembly. Remove the bearing (5).
- e. Use solvent to wash out old lubricants from the bearings.

**Warning:** If ultrasonic cleaning is used, limit the ultrasonic time to 3 or 4 seconds, otherwise permanent bearing damage may occur.

- f. Ensure that both bearings are dry and free of solvents.
- g. Lubricate both bearings with eight drops of high temperature lubricating fluid in each bearing. Rotate the inner races several turns to distribute the fluid.

- h. Replace the bearing (5) in the thimble assembly.
- i. Refit the spiral retaining ring (4), ensuring it is fully seated in its groove
- j. Refit the outer thimble assembly, complete with bearing (2) onto the drive body. Replace the circlip (1). Ensure that the thimble rotates freely.
- k. Clean off unwanted lubrication marks with solvent.



#### 4.3 Factory Servicing of Rotary Drives

Rotary Drives may be returned to the factory or local service agent. It is not recommended that the user attempts to dismantle or repair a damaged drive. Items for return should be accompanied by an order giving full details of the service required and a completed 'Declaration of Contamination' form (a copy of which can be found at the end of this handbook).

**Warning:** Do not attempt to remove magnets from the drive.

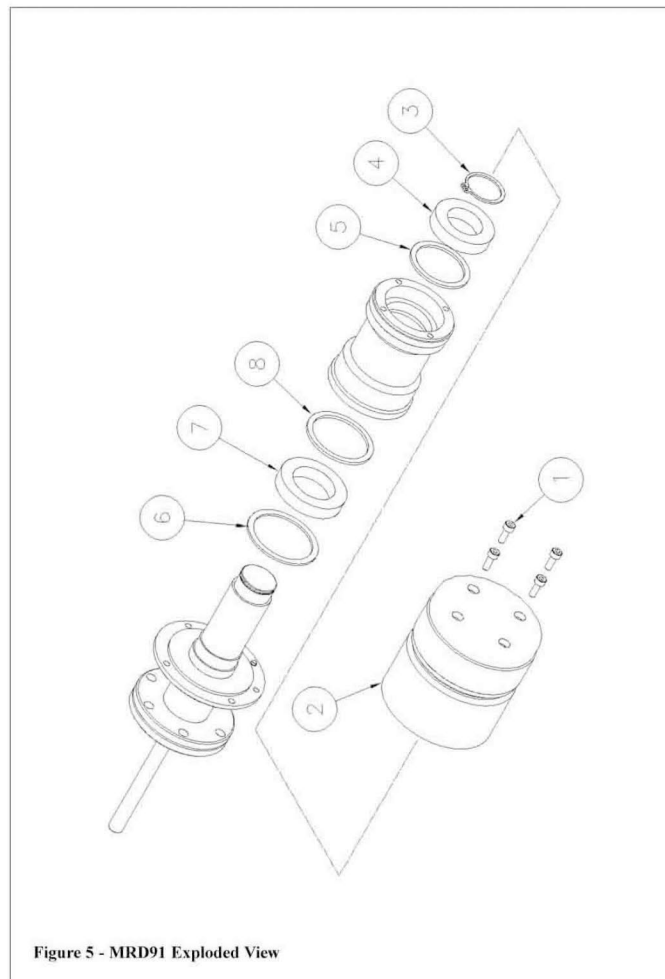

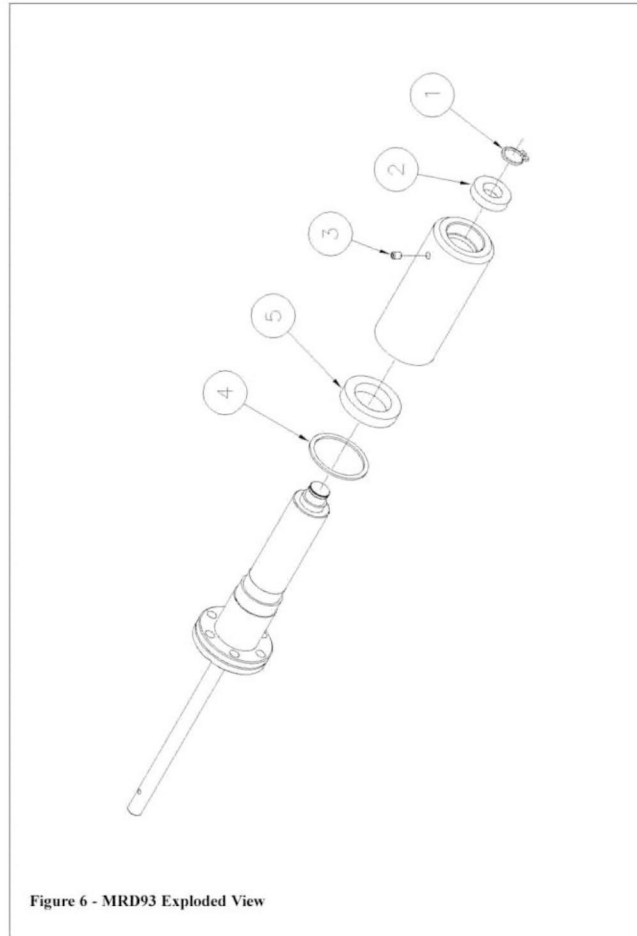

Figure 6 - MRD93 Exploded View

## 5. SPARES AND ACCESSORIES



### 5.1 General

Gaskets: The large selection of gasket types shown below is available for standard CF flange sizes.

- \* Super quality copper (CU series)
- \* Commercial user copper (CUC series)
- \* Annealed high quality copper (CUA series)
- \* Silver plated copper (CUSP series)
- \* Viton (VIT series)
- \* Aluminium (AL series)

Nut, Bolt and Washer sets: Metric sets are available for most flange combinations. Please contact VACGEN for more information.

Tool kit: ZTOOLK for general use. Includes a wide range of spanners and ball-ended hexagon keys, circlip pliers, small screwdriver and nylon gloves.

Lubrication kit: ZLUBEK for general use. Includes high temperature grease and lubricant, non-ozone depleting solvent, thread lubricant and nylon gloves.

### 5.2 Rotary Drive Spares & Accessories

Order Code	Description
ZMRD91MK	Stepper motor primary rotation kit (ZMRD91)
ZMRD6MK	Stepper motor primary rotation kit (ZMRD6)
ZMRD91DK	DC motor primary rotation kit (ZMRD91)
ZMRD6DK	DC motor primary rotation kit (ZMRD6)
ZSAC and ZMAC ranges	Stepper motor controllers
Motor wiring accessories	Refer to Motor Spares in Appendix A for cables and connectors used with VACGEN motor controllers.

For other parts, please contact VACGEN with your model type and serial number.



## APPENDIX A. STEPPER MOTOR CONNECTIONS

### AI. OVERVIEW

Motors and encoders used in VACGEN equipment achieve their intended performance with VACGEN controllers (SDU, SMC or SMC-E) and no responsibility can be accepted should performance be inadequate when other controllers are used.

For attachment to VACGEN controllers, the motors (and encoders if applicable) can be supplied wired with suitable connectors. Otherwise, motors are supplied without connectors to allow connection to alternative drive and controller systems.

All motor variants are 4 phase, 8-lead hybrid stepper motors that can be wired up in most normal configurations as shown below. Some motor kits may include microswitches.

For motors fitted with incremental encoders, the VACGEN SMC-E range of controllers is required to provide passive feedback. If the motor has no encoder fitted, the controller cannot be used in the "Loop Active" mode. Note that encoders cannot be retrofitted to motors.

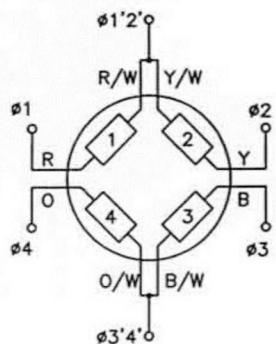

**UNI-POLAR:**  
Use only where low torque  
at low speed is sufficient.

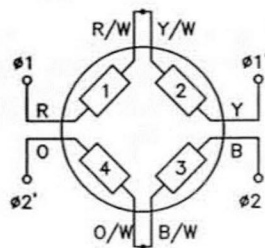

**BI-POLAR IN SERIES**  
Provides high torque  
at low speed.

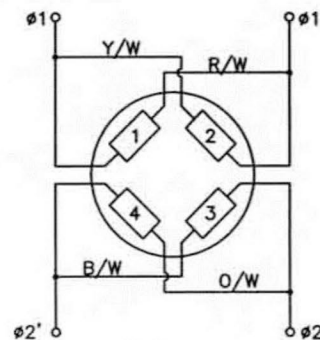

**BI-POLAR IN PARALLEL**  
Provides moderate torque  
at low and high speeds.

Key to Colour Coding:

Wire colours as follows.

R - Red, W - White, Y - Yellow, B - Black, O - Orange, G - Green

Alternative motors may be used, with alternative colours. Refer to the following sections.

## A2. MOTOR SPECIFICATION



Motor Type	Step angle	Step angle tolerance	Rotor inertia	Resistance per phase	Current per phase	Inductance per phase
23HS-108E	1.8 <sup>o(1)</sup>	5%	0.12 kg cm <sup>2</sup>	0.33	3.9A <sup>(2)</sup>	0.38mH
23HS-309E	1.8 <sup>o(1)</sup>	5%	0.23 kg cm <sup>2</sup>	0.40	4.7A <sup>(2)</sup>	0.84mH
23HS-409E	1.8 <sup>o(1)</sup>	5%	0.33 kg cm <sup>2</sup>	0.48	4.6A <sup>(2)</sup>	1.00mH
34HS-109E	1.8 <sup>o(1)</sup>	5%	0.67 kg.cm <sup>2</sup>	0.45	4.7A <sup>(2)</sup>	1.30mH
34HS-209E	1.8 <sup>o(1)</sup>	5%	11.30 kg cm <sup>2</sup>	0.55	4.6A <sup>(2)</sup>	2.50mH

### Notes:

(1) Step angle quoted for full step drive. VACGEN controllers use half step drives with step angle being 0.9<sup>o</sup>.

(2) Limit the maximum current to the following values, determined by the drive used.

(Note that running at maximum current can cause motor to run hot and can give rise to resonance.)

\* Maximum current/phase for unipolar drive = rated current.

\* Maximum current/phase for bi-polar in series = 0.70 x rated current.

\* Maximum current/phase for bi-polar in parallel = 1.4 x rated current.

## A3. COLOUR CODING OF MOTOR WIRES

### Key to Colour Coding:

R - Red, W - White, Y - Yellow, B - Black, O - Orange, G - Green

	As Drawn	Alternative 1	Alternative 2
Phase 1	R	R	R
	R/W	B	Purple
Phase 1'	Y	R/W	Y
	Y/W	W	Blue
Phase 2	B	G/W	Pink
	B/W	B/W	Grey
Phase 2'	O	G	B
	O/W	O	W

Alternative motors may be used. Wire colours as follows



Series Motor Wiring

Parallel Motor Wiring

### A4. WIRING

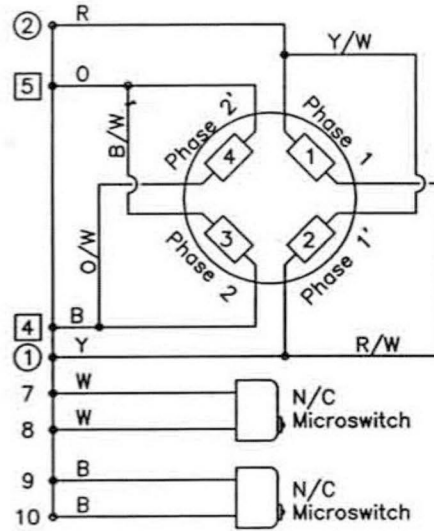
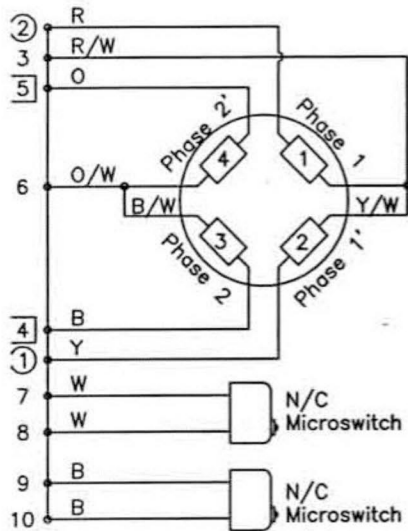

### MOTOR

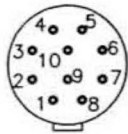

These diagrams show connections for compatibility with Vacuum Generators motor controllers.

Socket used is ref. XSOC24 (Series and parallel connection).

Series connection is preferred for high torque at low speed. Parallel connection is used for higher speed applications.

Where microswitches are not used, links must be made between pins 7 and 8, and between pins 9 and 10.

If the rotation direction is opposite to that required, reverse the connections on pins 1 and 2.

Twist together phase pairs to reduce electro-magnetic emission, i.e.: ① and ②, and ④ and ⑤.

### DIAGRAMS

**Caution:** When wiring motors, care must be taken to make all connections secure. Failure to do so may result in disconnection during use and this can permanently damage the motor drive. For the same reason, never disconnect a motor from its drive unless the power has first been switched off.

Refer to previous section for colour coding of wires.

Wiring diagrams for motors suitable for VACGEN Controllers

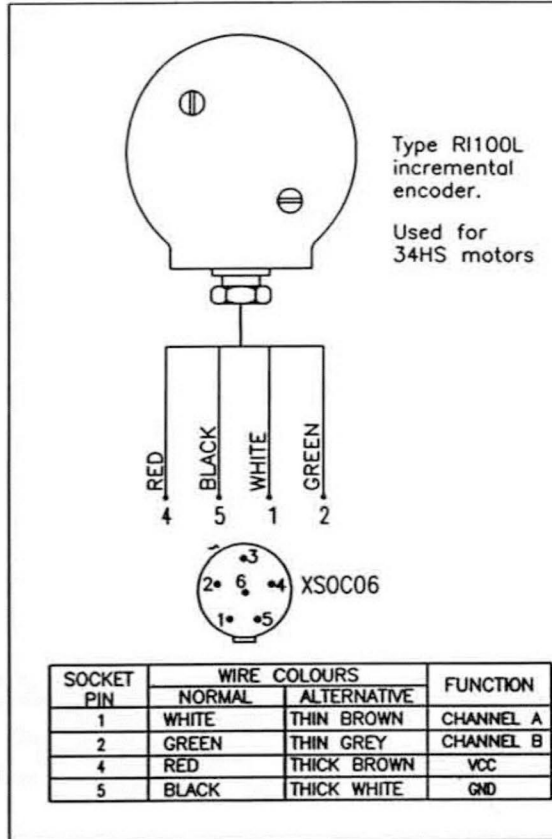
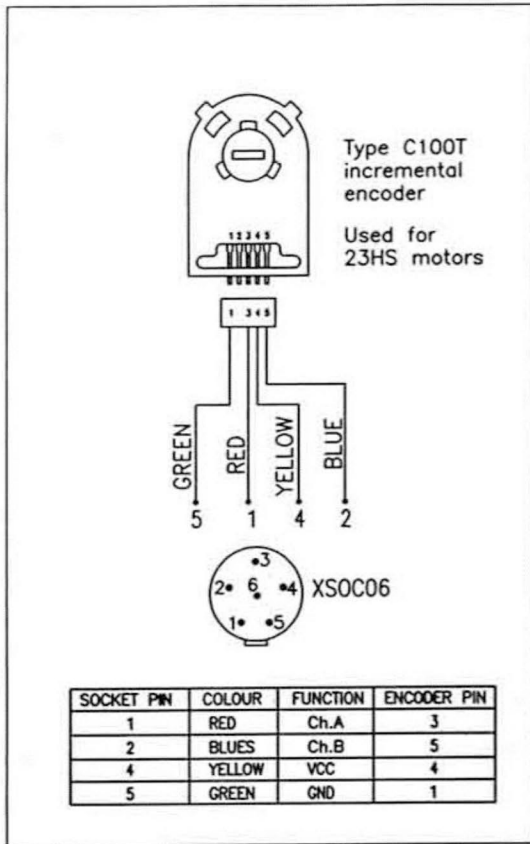

**A5. ENCODER WIRING DIAGRAMS**

Wiring diagrams for incremental motor encoders.

**Service and Repair Form**



<b>Declaration of Contamination of Equipment and Components</b>	
<p>Servicing and repairs will only be carried out if the conditions for Servicing and Repair are complied with in full, according to the VACGEN Ltd. Conditions of Sale. A summary of these requirements are included on the inside front cover of the Operating Instructions. The manufacturer will refuse to accept any equipment without a signed declaration attached to the OUTSIDE of the packaging. This declaration can only be completed and signed by authorized and qualified staff.</p>	
<b>1 Description of Equipment and Components</b>	
<p>Equipment Type..... Model Number.....                  Serial Number..... Your Reference Number.....</p>	
<b>2</b>	<b>Reasons</b>
<b>return</b> .....	<b>for</b>
.....	.....
.....	.....
.....	.....
.....	.....
<b>3 Condition of Equipment</b>	
YES ( ) NO ( ) Toxic?	YES ( ) NO ( ) Corrosive?
YES ( ) NO ( ) Explosive?	YES ( ) NO ( ) Biological Hazard?
YES ( ) NO ( ) Radioactive?	YES ( ) NO ( ) Other Harmful Substances?
<p>Equipment and Components that have been contaminated, WILL NOT be accepted without written evidence of decontamination.</p>	
<b>5 Contamination Materials</b>	
<p>List all the substances, gases and by-products that may have come in contact with the equipment, giving trade name, manufacture, chemicals names or symbols.                  Please note that any of these listed, must be completely removed, so it is safe to handle and weld, without giving off health threatening gases. Please enter details below and/or attach data sheets</p> <p>.....</p> <p>.....</p> <p>.....</p>	
<b>6 Legally Binding Declaration</b>	
<p>I hereby declare that the information supplied on this form is complete and accurate.                  There by stating that the goods offer no risk to health or safety</p> <p>Organisation..... Name.....                  Country..... Job Title.....                  Post/ZIP code..... Telephone.....                  Email.....</p> <p>Signature..... Date.....</p>	
<p>Return goods to: Address at top                  Phone: (0) 1424 851291 Fax (0) 1424 851489 (Form VGF33)</p>	