

Operating and Maintenance Handbook

Wiring Information for Stepper Motors and SIMSTEP Controller



WWW.JEVINSTRUMENTS.COM



Revision History

Revision	Date	Comment	Initials
1	June 2019	Original Release	DRM

Copyright Notice: 2019 by VACGEN Ltd. All rights reserved. Information contained in this handbook is subject to change without notice and does not represent a commitment on the part of VACGEN Ltd. No part of this document may be copied, distributed, transmitted, transcribed, stored in a retrieval system or translated into any human or computer language, in any form or by any means, electronic, mechanical, magnetic, optical, manual or otherwise or disclosed to third parties without the express written of VACGEN Ltd, Diamond Drive, Hailsham, East Sussex, BN27 4EL, UK

1. INTRODUCTION

1.1 HEALTH AND SAFETY INFORMATION

This equipment is a component for use with vacuum systems. Whilst every effort has been made to eliminate hazards, its safe use is also dependant on the system to which it will be connected.

The owner of the equipment must ensure that all users are aware of the Health and Safety information contained in this handbook. If the equipment is sold or passed to another owner, this handbook must be included with the equipment. If in doubt contact VACGEN.

Warning: This equipment must be repaired/installed by qualified personnel.

Warning: It is the responsibility of the user to consider the safety requirements of hazardous materials used with this equipment and the consequence of any leakage, however caused. Consider possible reactions with materials of construction. Any equipment returned to VACGEN must have the correct Declaration of Contamination securely fastened to the outside of the packaging.

Warning: Harmful gases may be evolved if this equipment is heated to temperatures above the maximum specified bakeout temperature.

Warning: Lubricants used in this assembly may cause irritation to sensitive skin. Wear protective clothing.

Warning: Where cryogenic liquids are used with the equipment, it is the responsibility of the user to ensure that the correct safety precautions are taken when handling and storing these materials.

Warning: Safe disposal of the equipment is the responsibility of the user.

Warning: It is the responsibility of the user to fit emergency stops to automated equipment.

Warning: Keep clear of moving parts.

Warning: Do not use this equipment with positive internal pressure above the specified maximum.

Warning: Some equipment may develop extreme hot or cold surfaces. Wear protective clothing.

Warning: Equipment must be fully earthed to prevent dangerous electrostatic charge build-up.

WARRANTY

Subject to fair wear and tear and the due observance of any installation, user, storage, operating or maintenance instructions the Seller undertakes to replace or at its option repair free of charge to the Purchaser any goods which the Purchaser can establish are defective by reason of defective workmanship or materials and which are returned to the Seller carriage paid within 12 months of the date of dispatch by the Seller. In the event, however, that the Seller supplies spare parts either direct or are fitted or installed or replaced by the Seller's Service Centre such spare parts will be subject to warranty period of six months only.

1. The Purchaser cannot return any product for warranty repair without the prior approval of VACGEN and the issue of a Goods Return Number (GRN). This shall be obtained by contacting the service centre at VACGEN. All returned products must be accompanied by a completed Declaration of Contamination form (see note 2 below). Overseas customers must in the first instance contact the local selling agent.
2. We reserve the right to decline to service equipment we consider is in any way hazardous until a clearance or safety certificate, in a form satisfactory to VACGEN, has been completed and returned by the customer.

SERVICING AND REPAIR

The following additional terms and conditions apply in the event that the customer elects to use the services of VACGEN workshop on a chargeable basis.

- 1 At own cost the customer shall dispatch the equipment to the workshop, carriage paid, suitably packed, protected and insured, bearing a Goods Return Number (GRN) and a completed Health & Safety Certificate (see note 2 below) obtained from VACGEN in advance of shipment.
- 2 During the period the equipment is on VACGEN premises, VACGEN will ensure the equipment against all risks.
- 3 VACGEN will provide an acknowledgement of the receipt together with an estimate of the repair charges. Such estimates are carried out on a visual basis and are therefore intended as a guide only. Formal fixed price repair quotations are available and involve the disassembly of the equipment to determine the full extent of work necessary to restore the equipment to an acceptable standard. In the event that the customer chooses not to proceed with the repair, VACGEN will make a charge to cover this examination effort.

NOTE 1: The above are extracts from VACGEN Conditions of Sale. Complete copies can be obtained from: VACGEN Ltd, Diamond Drive, Hailsham, East Sussex, BN27 4EL, UK

NOTE 2: This product is exempt from requiring a Declaration of Contamination form, but the user is nevertheless responsible for ensuring that the product is safe for transportation and handling.

Service Department Direct Lines: Tel: +44 (0) 1323 379225



WWW.JEVINSTRUMENTS.COM



2. Introduction



This manual will cover all the Stepper Motor range as sold by VACGEN

More detail information for the SIMSTEP can be found at: < <https://vacgen.com/operating-instructions> >

Basic SIMSTEP software, McTerminal can be found at: < <https://vacgen.com/operating-instructions> >

3. Motors

This chart is a guide for the motor type for the component it is mounted on.

Component	Motor Part Code	Description	Motor/Encoder Part Code	Description
ZLVM	XMOT05A	MOTOR STEPPER 23HSX-102E	Not Used	
ZRD91	XMOT05W	STEP/MOT 23HS-108E	XMOT38AW	STEP/MOT 23HS-108E + CI500I
ZRD6, 7	XMOT33W	STEP/MOT 23HS-309E	XMOT35AW	STEP/MOT 23HS-309E + CI500I
ZRD1, 2 Primary	XMOT05W	STEP/MOT 23HS-108E	XMOT38AW	STEP/MOT 23HS-108E + CI500I
ZRD2 Secondary	XMOT05W	STEP/MOT 23HS-108E	XMOT38AW	STEP/MOT 23HS-108E + CI500I
DPRF25	XMOT05W	STEP/MOT 23HS-108E	XMOT38AW	STEP/MOT 23HS-108E + CI500I
DPRF55	XMOT33W	STEP/MOT 23HS-309E	XMOT35AW	STEP/MOT 23HS-309E + CI500I
ZLTM	XMOT12W	STEP/MOT 23HS-108E 10:1 S60	XMOT41AW	STEP/MOT 23HS-108E 10:1 S60 + CI500I
ZLTM Wide Bore	XMOT33W	STEP/MOT 23HS-309E	XMOT35AW	STEP/MOT 23HS-309E + CI500I
ZRP100	XMOT33W	STEP/MOT 23HS-309E	XMOT35AW	STEP/MOT 23HS-309E + CI500I
ZLDS	XMOT05W	STEPPER MOTOR 23HS-108E	XMOT38AW	STEP/MOT 23HS-108E + CI500I
ZTR (Z Only)	XMOT02AW	STEP/MOT 23HS-409E	XMOT44AW	STEP/MOT 23HS-409E + CI500I
HPT-RX/WX - X,Y & Z	XMOT05W	STEP/MOT 23HS-108E	XMOT38AW	STEP/MOT 23HS-108E + CI500I
Transax - Z	XMOT02AW	STEP/MOT 23HS-409E	XMOT44AW	STEP/MOT 23HS-409E + CI500I
Transax - X&Y	XMOT33W	STEP/MOT 23HS-309E	XMOT35AW	STEP/MOT 23HS-309E + CI500I
Omniax - Z	XMOT31W	STEP/MOT 34HS-209	XMOT37W	STEP/MOT 34HS-209 + CI500I
Omniax - Z Later Version	XMOT94W	STEP/ MOT 23HSX-306E	XMOT95AW	STEP/MOT 23HSX 306 + CI500I
Omniax - X&Y	XMOT33W	STEP/MOT 23HS-309E	XMOT35AW	STEP/MOT 23HS-309E + CI500I
Centiax - Z	XMOT56AW	STEP/MOT 34HSX312	Not Used	
Centiax - X&Y	XMOT33W	STEP/MOT 23HS-309E WIRED	XMOT35AW	STEP/MOT 23HS-309E WIRED + CI500I*

*Encoders are CI500I 500-line count encoders

17 & 23 frame size hybrid stepper motors

HS series

The hybrid stepper motors in the range conform to the international NEMA standard and provide 200 steps /rev when used with full step drives or 400 steps per revolution in the preferred half step drive mode. The internal construction has also been optimised for microstepping resulting in improved smoothness of operation. Where increased torque and resolution is required at reduced speed a range of gearheads are available. The motors are suitable for use with either Uni-polar or Bi-polar drive circuits, the 23HS series having 8 leads to provide the choice of parallel or series connection. Despite the high quality of the latest generation **HS series**, the units remain competitively priced. The 23HS series offer a choice of single or double shaft when encoders or parking brakes are required and a wide range of drive and control modules are available to construct complete high performance systems.



Dimensions mm

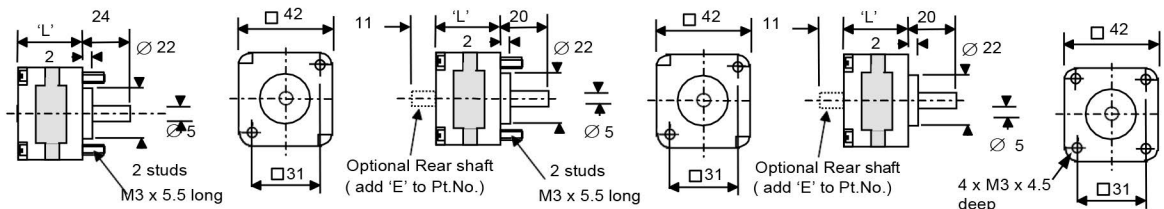

17HS:

Style A

Style B

Style C

23HS Series

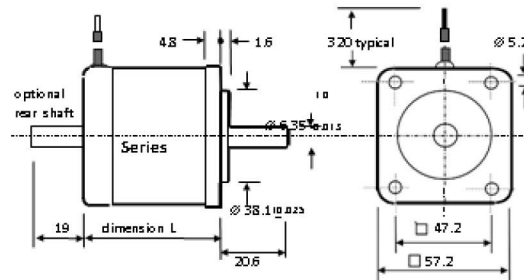

JEVI
VACUUM
INSTRUMENTS

WWW.JEVINSTRUMENTS.COM



Specification: 17HS & 23HS series 1.8 degree stepper motors

motor type	length 'L' mm	Style	holding torque Ncm	rotor inertia Kgcm ²	resistance per phase ohms	current per phase amps	inductance per phase mH	number of leads	mass Kg
17HS-006 Mk 3	34	A	11.2	0.018	36	0.26	17	6	0.2
17HS-008	34	B	1.2	0.018	15.6	0.4	11.9	6	0.2
17HS020E	34	A	9.0	0.019	2	1.0	1.1	6	0.2
17HS020E Mk 2	34	C	14	0.018	5.6	1.0	8.5	4	0.2
23HS-030	38.7		25	0.077	1.6	1.5	1.6	6	0.36
23HS-104** Mk 2	52		52	0.124	1.1	2.0	1.7	8	0.5
23HS-104 E	50.8		38	0.115	1.1	2.0	2.0	8	0.5
23HS-108 **Mk 2	52		52	0.124	0.37	3.9	0.59	8	0.5
23HS-108 E	50.8		38	0.115	0.37	3.9	0.59	8	0.5
23HS-202 E	56		50	0.135	5.0	1.0	9.5	8	0.55
23HS-304 **Mk 2	67		89	0.200	1.8	2.0	3.3	8	0.7
23HS-309 **Mk 2	67		87	0.200	0.33	4.7	0.50	8	0.7
23HS-309 **	76.2		95	0.239	0.37	4.7	0.73	8	0.95

Note ** Rear shaft may be specified by adding 'E' to part number EXAMPLE: 23HS-304E Mk 2

34 frame size hybrid stepper motors

34HS series

The 34HS series hybrid stepper motors in the range conform to the international NEMA standard and provide 200 steps /rev when used with full step drives or 400 steps per revolution in the preferred half step drive mode. Where increased torque and resolution at reduced speed is required a comprehensive range of planetary gearheads may be specified. The internal construction has also been optimised for microstepping resulting in improved smoothness of operation. Suitable for use with either Uni-polar or Bi-polar drive circuits, the motors incorporate design features such as loop-less termination of the motor windings to internal circuit boards for increased reliability. Despite the high quality of the latest generation **34HS series**, the units remain competitively priced and offer a choice of single or double shaft when encoders or parking brakes are required.



A comprehensive range of drive and control modules are available for use with HS series motors. These conform to the International Eurocard standard and may be purchased in modular form or as a complete racked system depending on customer choice.

Dimensions mm

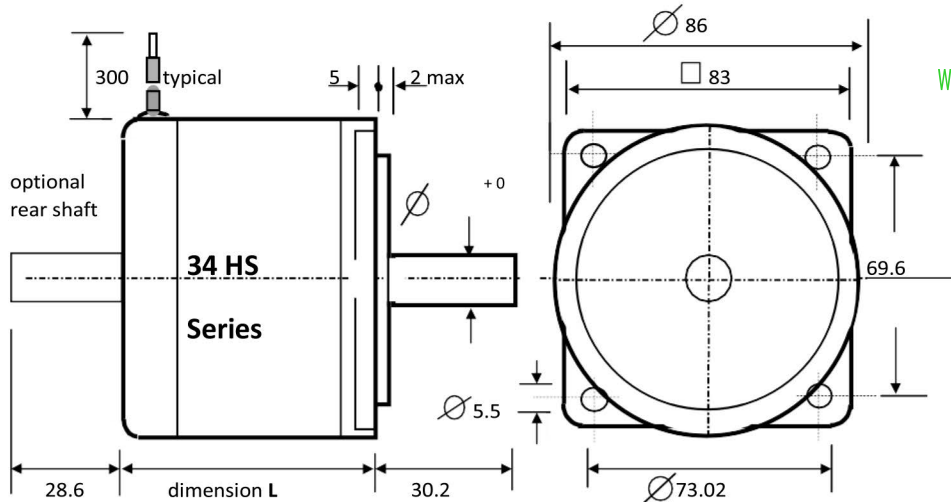

JEVI
VACUUM
INSTRUMENTS

WWW.JEVINSTRUMENTS.COM



Specifications: 34HS 1.8 degree stepper motors

motor type	length 'L' mm	holding torque Ncm	rotor inertia Kgcm ²	resistance per phase ohms	current per phase amps	inductance per phase mH	number of leads	mass Kg
34HS-106 **	62.3	120	0.63	0.95	3.1	3.2	8	1.5
34HS-109 **	62.3	120	0.63	0.45	4.7	1.3	8	1.5
34HS-209 **	94.25	220	1.33	0.55	4.6	2.5	8	2.58

Note ** Rear shaft may be specified by adding 'E' to part number EXAMPLE: **34HS-209E**

Typical HS series stepper motor performance

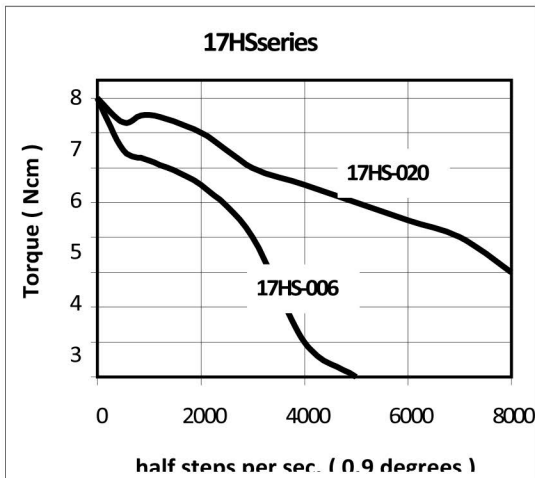

Uni-polar drive with 24 Vdc supply

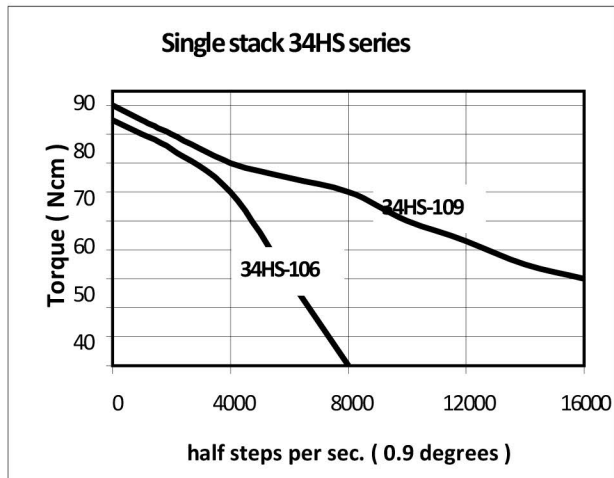

Bi-polar drive with coils in parallel

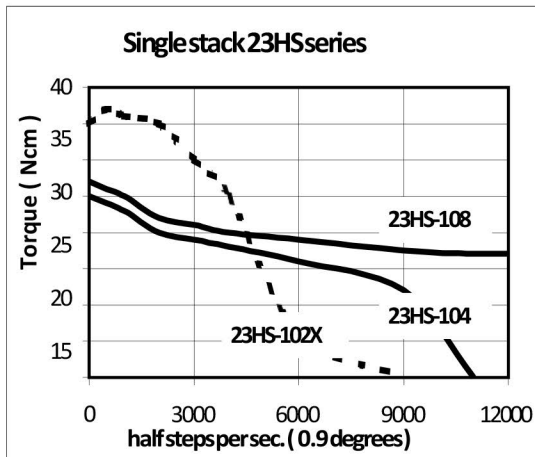

Bi-polar drive with coils in parallel

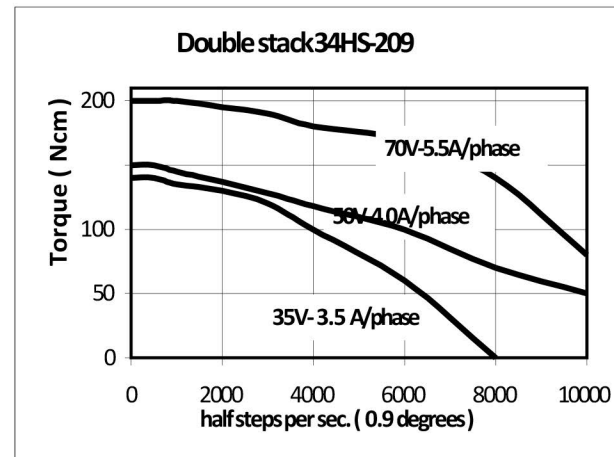

Bi-polar drive with coils in parallel

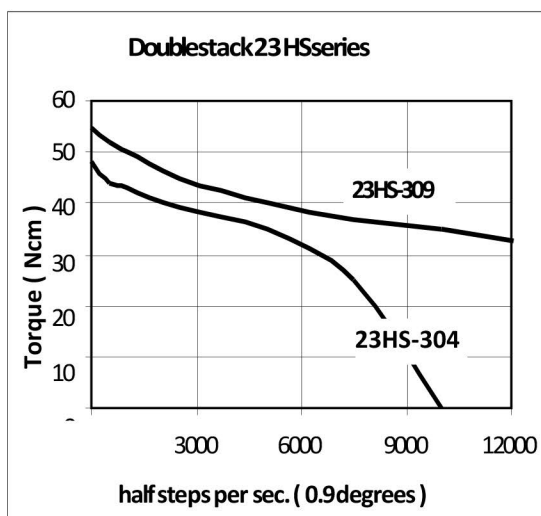

Bi-polar drive with coils in parallel

JEVI
VACUUM
INSTRUMENTS

WWW.JEVINSTRUMENTS.COM



For increased torque at low speed the motors may be connected with their coils in series

Hybrid stepper motors with integral encoders HS series



The 23HS & 34HS stepper motors are available fitted with dual track encoders to provide feedback of motor position. Motors thus equipped are therefore ideally suited for use with motion systems employing closed loop controllers such as PM341 & PM600.

Two encoders types CI & RI series are available, which may be specified with the 23HS motors & 34HS types as shown below. Since the controllers monitor each signal transition on each of the encoder's A & B tracks, a line count of 100 ppr provides a measuring resolution of 400 steps/rev while a 500 ppr encoder is used with 2000 step per rev. microstepping drives.



Where customers require an encoder for use with control systems not supplied by McLennan and which require alternative line-counts, the model 'RI' encoder is available with any line count required up to a maximum value of 2,000 ppr. resulting in a measuring resolution of 8,000 steps/rev.

Encoder signals:

The CI...T encoder provides a 5V TTL output signal and is suitable for instrumentation applications where the encoder is to be sited no further than 5 meters from the measuring electronics.

The CI...L & RI ...L encoders are equipped with a 5V line driver output suitable for industrial installations where the motor- encoder may be up to 50 meters away from the measuring electronics providing the encoder lead is correctly screened.

Dual track output	pulses/rev	index	motor steps/rev	motor type	Encoder type
A B	100	-	400	23HS...	CI 100T
A B	500	-	2000	23HS...	CI..500T
\overline{A} \overline{A} \overline{B} \overline{B}	500	C C	2000	23HS...	CI 500L
\overline{A} \overline{A} \overline{B} \overline{B}	100	C C	400	34HS.	RI 100L
\overline{A} \overline{A} \overline{B} \overline{B}	500	C C	2000	34HS...	RI 500L

Stepper motor fitted with CI encoder

RI...L encoder

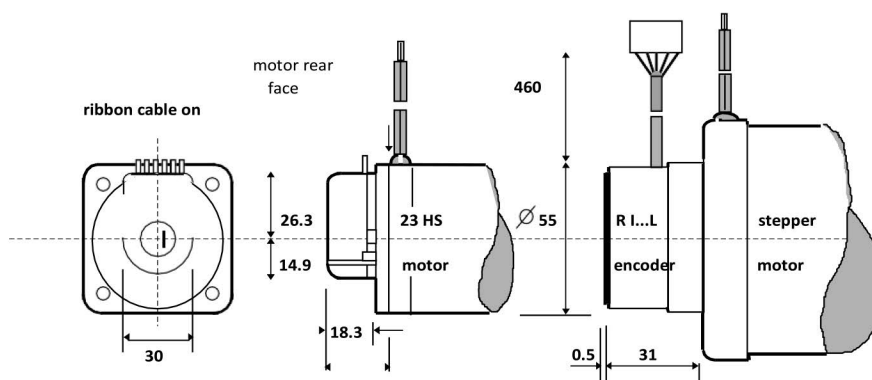



6. Wiring Motor and Microswitches

	Tolerances Unless Otherwise Stated	0 Decimal Places +/- 0.5 1 Decimal Place +/- 0.25 2 Decimal Places +/- 0.10	Angles +/- 2 Deg.	Material -	Finish -	RevNo -	Revision note -	Date -	By -	Checked -
--	---------------------------------------	---	-------------------	---------------	-------------	------------	--------------------	-----------	---------	--------------

4pin "Twistlock" pin Cable socket
R6 part # 463-683

Finished Length = 1M

Wire is 2 strands each of Black 7/0.2 and White 7/0.2 twisted to 1 twist per CM

Black (2)
White (2) XSIMS04

4pin "Twistlock" pin Cable socket
R6 part # 463-683

Finished Length = 300mm

Wire is 2 strands each of Black 7/0.2 and White 7/0.2 twisted to 1 twist per CM

Black
White XSIM03

Microswitch = XMIS13 (R6 333-322)

4pin "Twistlock" pin Cable socket
R6 part # 463-683

Finished Length = 300mm

Wire is 2 strands each of Black 7/0.2 and White 7/0.2 twisted to 1 twist per CM

Black
White XSIM01

Microswitch = 18X1-T (R6 334-361)

4pin "Twistlock" pin panel socket
R6 part # 463-426

Finished Length = 2M

Wire is 2 strands each of Black 7/0.2 and White 7/0.2 twisted to 1 twist per CM

Black (2)
White (2) XSIM02

Shave all joints with hexagonal

<p>© 2007 McLennan Servo Supplies Ltd.</p>	McLENNAN SERVO SUPPLIES LTD. Unit 1, The Royston Centre Lynchford Road, Ash Vale, GU12 5PQ Tel: 08707 700700 / Fax: 08707 700699 WWW.MCLENNAN.CO.UK	Dimensions in mm to BS308, DO NOT SCALE	Scale Nts Sheet 2	Title VG Scienta - Limits Cables							
	<table border="1" style="width:100%; border-collapse: collapse;"> <tr> <th style="width:10%;">Name</th> <th style="width:10%;">Date</th> <th style="width:10%;">Sheet</th> <th style="width:10%;">Nts</th> </tr> <tr> <td>MD Hatch</td> <td>30/3/2007</td> <td>Next sheet</td> <td>-</td> </tr> </table>	Name	Date	Sheet	Nts	MD Hatch	30/3/2007	Next sheet	-	Drawing Number 4197 (4196)	Issue A
	Name	Date	Sheet	Nts							
	MD Hatch	30/3/2007	Next sheet	-							
Drawn G. Wingate	Date 13/4/2007	Next sheet -	Nts -								
Checked G. Wingate	Date 13/4/2007	Drawing Number 4197 (4196)	Issue A								

Finished Length = 300mm

Connector pin numbering

A	1
B	1'
C	2
D	2'
E	3
F	3'
G	4
H	4'

Motor Connections

For wire colours use
Dwg 3835

<p>© 2007 McLennan Servo Supplies Ltd.</p>	Scale Nts Sheet 1	Title VG Scienta - Generic XMOTxxW Data
	Next sheet -	Drawing Number 4196 (4196)
	Issue B	Issue B

7. Wiring Encoder

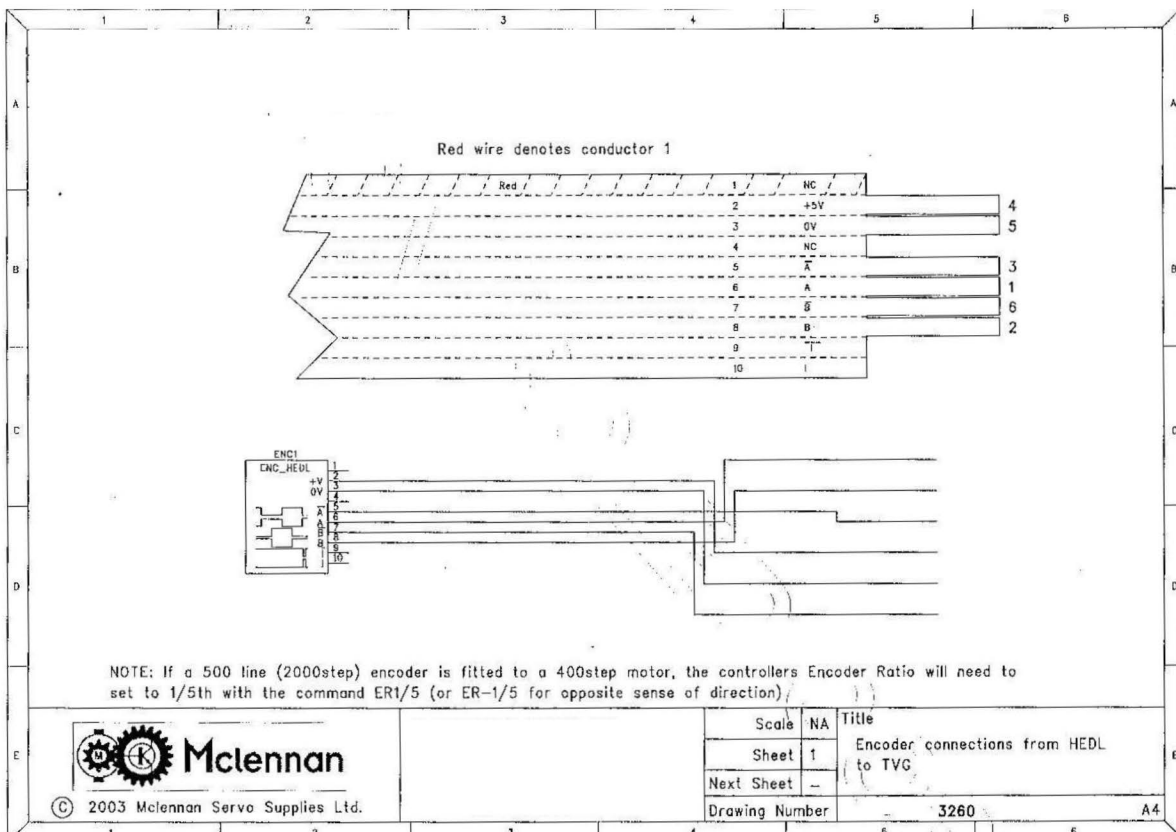
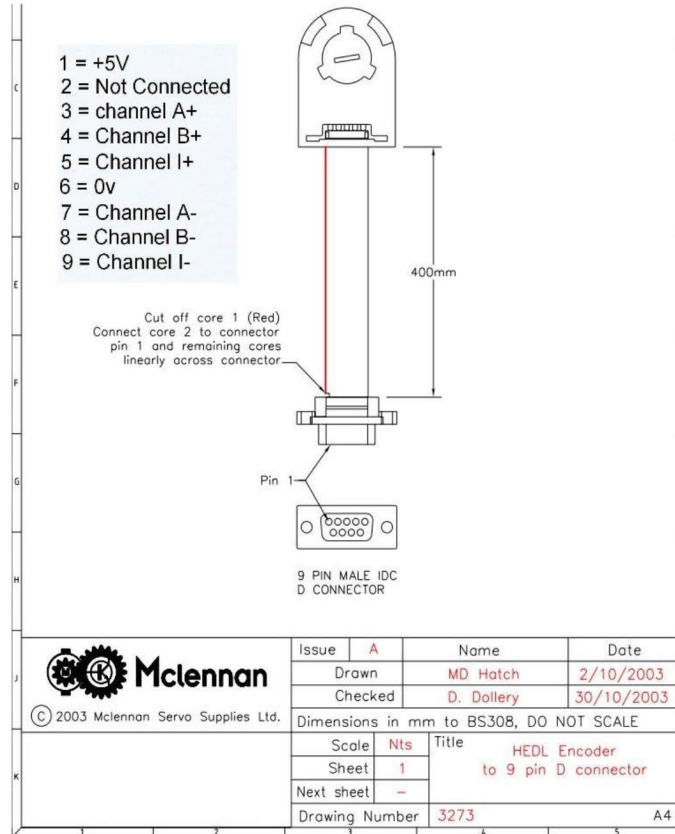
Latest 500-line count

Old Style Lemo Plug Wiring Diagram



DO NOT SCALE DRG

THIS DRAWING IS PRODUCED ON CAD.

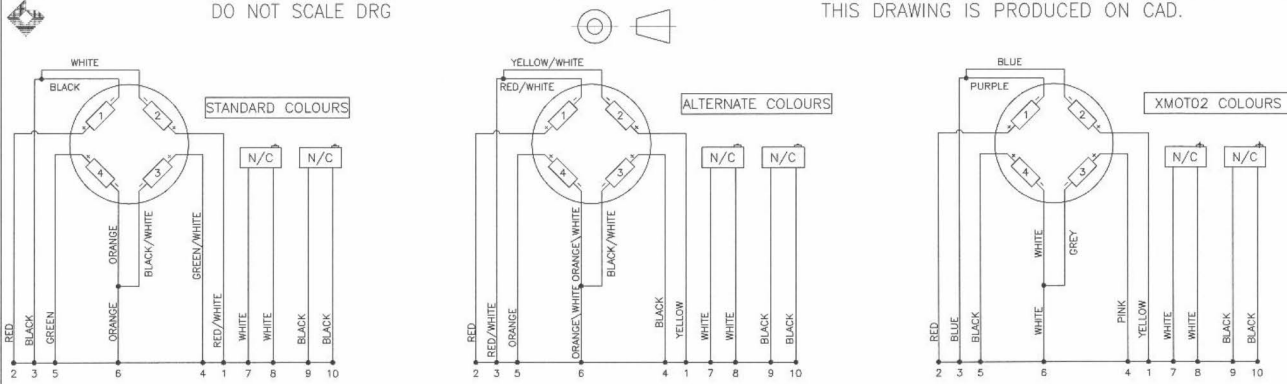

Series Wiring
For High Torque at Low Speeds

Old Lemo Plug Wiring

THIS DRAWING AND ANY INFORMATION OR DESCRIPTIVE MATTER SET OUT HEREIN IS THE PROPERTY OF JEVI VACUUM INSTRUMENTS AND MUST NOT BE DISCLOSED, REPRODUCED, COPIED, EITHER WHOLLY OR IN PART, OR FOR ANY OTHER PURPOSE, WITHOUT THEIR WRITTEN PERMISSION.

VIEW ON REAR OF SOCKET XS0625

Notes:

- 1-When joining phase leads, strip insulation from principal lead and solder with secondary lead. Cover with suitable insulation. Note that the position of these joints must be staggered.
- 2-Twist negative phases of poles 1 & 2 together and negative phases of poles 3 & 4.
- 3-Motor and microswitch leads to be sheathed to give a neat appearance.
- 4-Where microswitches are not required, provide link between pins 7 and 8, and between pins 9 and 10.

Convention:

'Clockwise' denotes a forward command of the controller which gives a clockwise motor rotation when looking at the back (non-flanged end).

			DIMENSIONS IN MILLIMETRES UNLESS OTHERWISE STATED	REMOVE ALL BURRS AND SHARP EDGES	VACGEN	
			0 50 MILLIMETRES FULL SCALE	SCALE NTS	TOLERANCE UNLESS OTHERWISE STATED	
			MATERIAL-		DIM'N 0 ± 1mm	
			FINISH-		DIM'N 0.0 ± 0.2mm	
			DRAWN BY RMS		SURFACE FINISH 1.6µ	
ECN3109	21/01/03	G			TITLE HS Motor Wiring Diag.	
ECN3091	22/10/02	G			DRG No SHT 1 of 2	
ECN2740	30/05/97	F			H2710	
ORIGINAL © Thermo Vacuum Generators	11/09/90	A			A	
REVISION	DATE	ISSUE			3	

DO NOT SCALE DRG

THIS DRAWING IS PRODUCED ON CAD.

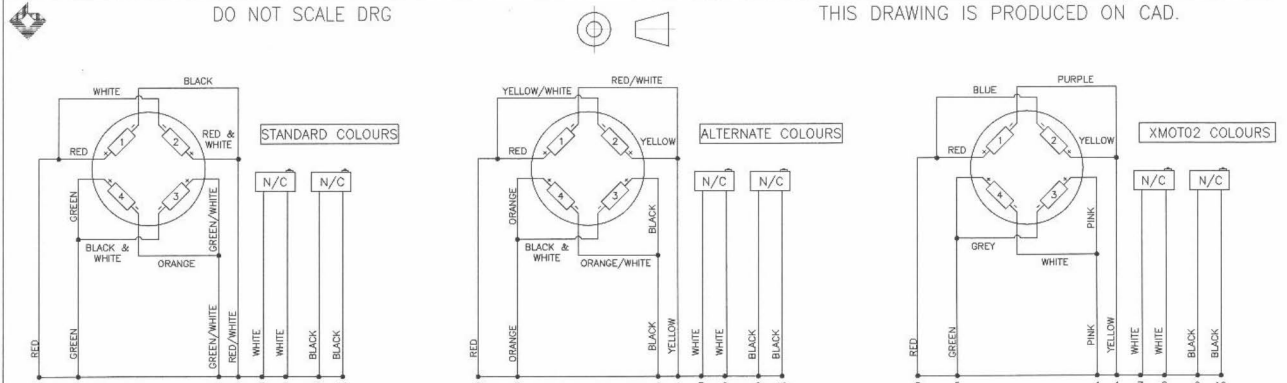

Parallel Wiring
For Moderate Torque at High Speeds

Old Lemo Plug Wiring

THIS DRAWING AND ANY INFORMATION OR DESCRIPTIVE MATTER SET OUT HEREIN IS THE PROPERTY OF JEVI VACUUM INSTRUMENTS AND MUST NOT BE DISCLOSED, REPRODUCED, COPIED, EITHER WHOLLY OR IN PART, OR FOR ANY OTHER PURPOSE, WITHOUT THEIR WRITTEN PERMISSION.

VIEW ON REAR OF SOCKET XS0625

Notes:

- 1-When joining phase leads, strip insulation from principal lead and solder with secondary lead. Cover with suitable insulation. Note that the position of these joints must be staggered.
- 2-Twist negative phases of poles 1 & 2 together and negative phases of poles 3 & 4.
- 3-Motor and microswitch leads to be sheathed to give a neat appearance.
- 4-Where microswitches are not required, provide link between pins 7 and 8, and between pins 9 and 10.

Convention:

'Clockwise' denotes a forward command of the controller which gives a clockwise motor rotation when looking at the back (non-flanged end).

			DIMENSIONS IN MILLIMETRES UNLESS OTHERWISE STATED	REMOVE ALL BURRS AND SHARP EDGES	VACGEN	
			0 50 MILLIMETRES FULL SCALE	SCALE NTS	TOLERANCE UNLESS OTHERWISE STATED	
			MATERIAL-		DIM'N 0 ± 1mm	
			FINISH-		DIM'N 0.0 ± 0.2mm	
			DRAWN BY RMS		SURFACE FINISH 1.6µ	
ECN3109	21/01/03	G			TITLE HS Motor Wiring Diag.	
ECN3091	22/10/02	G			DRG No SHT 2 of 2	
ECN2740	30/05/97	F			H2710	
ORIGINAL © Thermo Vacuum Generators	11/09/90	A			A	
REVISION	DATE	ISSUE			3	

Additional information for HSX Motors

High performance size 23 hybrid stepper motors

The high performance 23HSX series hybrid stepper motors conform to the international NEMA standard and provide 200 steps/rev when used with full step drives or 400 steps per revolution in the preferred half step drive mode.

Features:

- High energy Neodymium magnets for increased performance
- 50% more torque than conventional hybrid types
- Choice of single or double shaft options
- Optional encoder or parking brake.
- High quality & Economical prices
- Available with a choice of precision planetary gearheads for increased torque and resolution at reduced speed.
- 8 leads provide the choice of Uni-polar or Bi-polar operation
- Non-standard customised executions available to special order
- Wide range of matched drives and control modules enable complete systems to be economically constructed based on 'in-service proven' technology.

HSX series

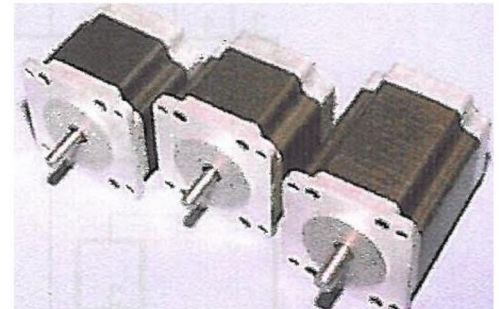

JEVI
VACUUM
INSTRUMENTS

WWW.JEVINSTRUMENTS.COM



Mechanical Specifications: 1.8 degree high performance stepper motors

motor type	length	Shaft diameter	number of leads	mass	Uni-polar Holding Torque	Bi-polar Holding Torque	Rotor Inertia
	'L' mm	'Ds' Mm		Ko	Nern	Nern	Ko cm ²
23HSX-102	41	6.35	8	0.5	37	47	0.077
23HSX-202 23HSX-206	55	6.35	8	0.7	75	98	0.22
23HSX-306	78.5	8.0	8	1.0	125	163	0.34

Electrical Specification:

motor type	Resistance per phase ohms	Current per phase Amps	Inductance per phase mH
23HSX-102	4.6	1.0	4.6
23HSX-202	6.2	1.0	8.8
23HSX-206	0.7	3.0	0.9
23HSX-306	1.1	3.0	1.7

Uni-polar operation

Current / phase Series connection Amps	Current / phase Parallel connection mH
0.7	1.4 max
0.7	1.4 max
2.1	4.2 max
2.1	4.2 max

Bi-polar operation

Note ** Read shaft may be specified by adding 'E' to part number EXAMPLE: 23HSX-206E

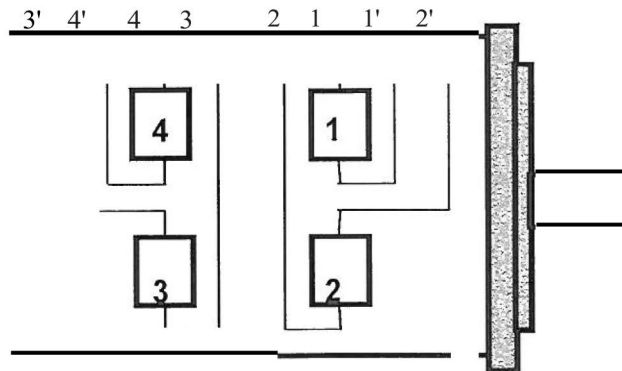
23HSX stepper motor lead colours:

Motor Types	lead or terminal identification							
Lead identity	1	1'	2'	2	3	3'	4'	4
23HSX 102 23HSX 202 23HSX 206 23HSX 306	Red	Red/ White	Yellow/ White	Yellow	Orange	Orange/ White	Brown/ White	Brown

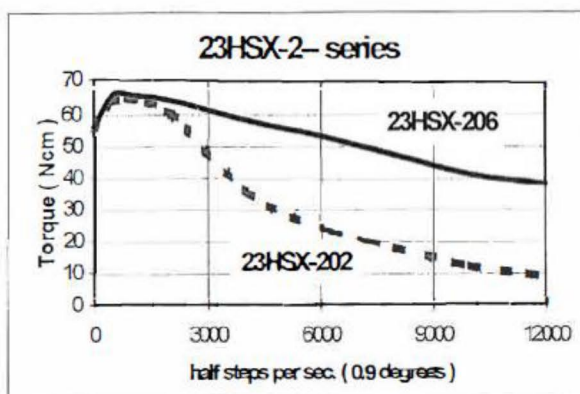
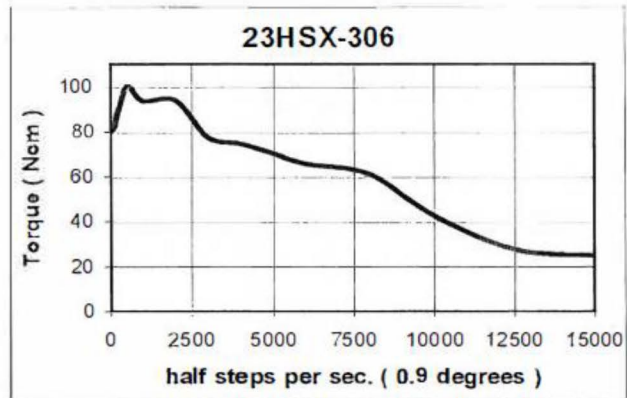
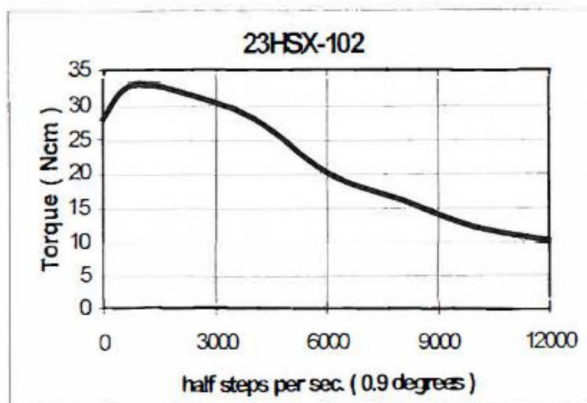
Typical Performance

Performance Curves
 Bi-polar operation, coils in parallel

Motor	Current Per phase (Amps)	Rail Voltage (Vdc)
23HSX-102	1.4	36
23HSX-202	1.4	36
23HSX-206	4.0	70
23HSX-306	4.0	70