

[WWW.JEVINSTRUMENTS.COM](http://WWW.JEVINSTRUMENTS.COM)



87-900-941-01(F)

05/2011

## Exhaust Filter

Model

DS-NW25 949-9392

**Manuale di istruzioni**

**User Manual**



**Agilent Technologies**

## Notices

© Agilent Technologies, Inc. 2011

No part of this manual may be reproduced in any form or by any means (including electronic storage and retrieval or translation into a foreign language) without prior agreement and written consent from Agilent Technologies, Inc. as governed by United States and international copyright laws.

## Manual Part Number

Publication Number: 87-900-941-01(F)

## Edition

Edition 05/2011

Printed in ITALY

Agilent Technologies Italia S.p.A.

Vacuum Products Division

Via F.lli Varian, 54

10040 Leini (TO)

ITALY

## Warranty

**The material contained in this document is provided “as is,” and is subject to being changed, without notice, in future editions. Further, to the maximum extent permitted by applicable law, Agilent disclaims all warranties, either express or implied, with regard to this manual and any information contained herein, including but not limited to the implied warranties of merchantability and fitness for a particular purpose. Agilent shall not be liable for errors or for incidental or consequential damages in connection with the furnishing, use, or performance of this document or of any information contained herein. Should Agilent and the user have a separate written agreement with warranty terms covering the material in this document that conflict with these terms, the warranty terms in the separate agreement shall control.**

## Technology Licenses

The hardware and/or software described in this document are furnished under a license and may be used or copied only in accordance with the terms of such license.

## Restricted Rights Legend

If software is for use in the performance of a U.S. Government prime contract or subcontract, Software is delivered and licensed as “Commercial computer software” as defined in DFAR 252.227-7014 (June 1995), or as a “commercial item” as defined in FAR 2.101(a) or as “Restricted computer software” as defined in FAR 52.227-19 (June 1987) or any equivalent agency regulation or

contract clause. Use, duplication or disclosure of Software is subject to Agilent Technologies’ standard commercial license terms, and non-DOD Departments and Agencies of the U.S. Government will receive no greater than Restricted Rights as defined in FAR 52.227-19(c)(1-2) (June 1987). U.S. Government users will receive no greater than Limited Rights as defined in FAR 52.227-14 (June 1987) or DFAR 252.227-7015 (b)(2) (November 1995), as applicable in any technical data.

## Trademarks

Windows and MS Windows are U.S. registered trademarks of Microsoft Corporation.

## Safety Notices

### CAUTION

A **CAUTION** notice denotes a hazard. It calls attention to an operating procedure, practice, or the like that, if not correctly performed or adhered to, could result in damage to the product or loss of important data. Do not proceed beyond a **CAUTION** notice until the indicated conditions are fully understood and met.

### WARNING

A **WARNING** notice denotes a hazard. It calls attention to an operating procedure, practice, or the like that, if not correctly performed or adhered to, could result in personal injury or death. Do not proceed beyond a **WARNING** notice until the indicated conditions are fully understood and met.



WWW.JEVINSTRUMENTS.COM



# Exhaust Filter



WWW.JEVINSTRUMENTS.COM



## Exhaust Filter

# Contents

## **1 Istruzioni per l'uso 7**

Descrizione del filtro disoliatore	8
Caratteristiche tecniche	8
Dimensioni di ingombro	9
Funzionamento	10
Installazione del filtro disoliatore	11
Manutenzione	11
Parti di ricambio ed accessori	12
Smaltimento	13

## **2 Instructions for Use 15**

Description of the Exhaust Filter	16
Technical Specification	16
Outline Drawing	17
Operation	18
Exhaust Filter Installation	19
Maintenance	19
Replacement Parts and Accessories	20
Disposal	21

## Contents

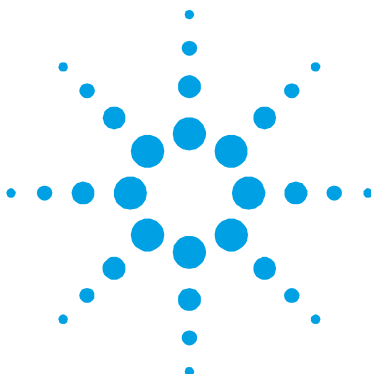

# 1

## Istruzioni per l'uso

Descrizione del filtro disoliatore	8
Caratteristiche tecniche	8
Dimensioni di ingombro	9
Funzionamento	10
Installazione del filtro disoliatore	11
Manutenzione	11
Drenaggio dell'Olio	11
Cambio della Cartuccia	11
Parti di ricambio ed accessori	12
Smaltimento	13

Traduzione delle istruzioni originali



## Descrizione del filtro disoliatore

Il filtro di intrappolamento olio NW 25 utilizza cartucce disolianti ad alta efficienza ed ha lo scopo principale di purificare i gas di scarico dagli aerosol di olio e di eventuali altri liquidi.

### AVVERTENZA!



Sostanze allo stato gassoso e di vapore non vengono trattenute dal filtro per cui eventuali gas tossici provenienti dalla pompa devono essere smaltiti allo scarico del filtro in accordo alle norme generali per la protezione contro gas velenosi.

## Caratteristiche tecniche

La seguente tabella dettaglia le principali caratteristiche del filtro disoliatore.

Tab. 1

	DS NW25
Massimo flusso a 1 bar e 20 °C [Nm <sup>3</sup> /h]	90
Caduta di pressione [mbar]	150
Massima pressione permessa [bar]	1.0
Flangia di aspirazione/ scarico	25 KF
Pompe su cui montare il filtro	DS 102 / 202 / 302 / 402 / 602



## Dimensioni di ingombro

La figura seguente mostra le dimensioni di ingombro del filtro disoliatore (le dimensioni sono in pollici [mm]).

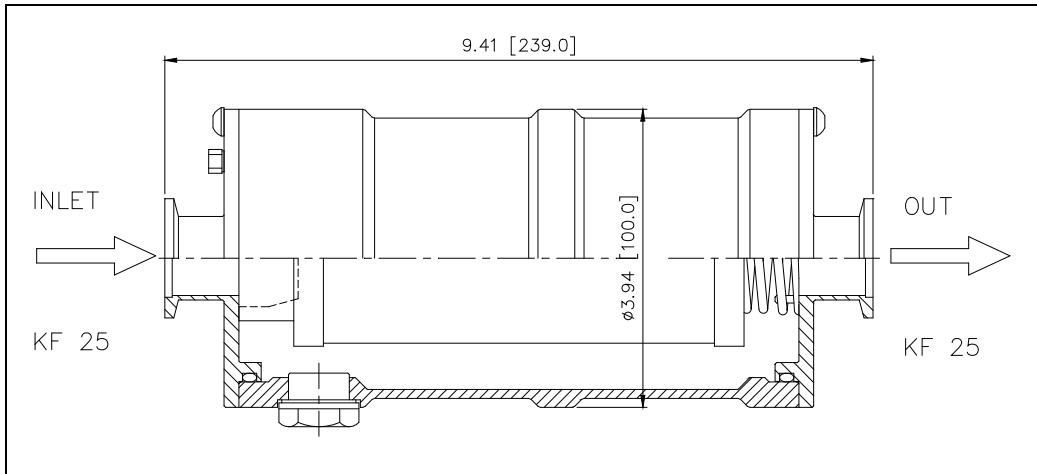

**Figura 1** Modello 949-9392

## Funzionamento

Per questa descrizione, fare riferimento alla figura seguente.

Il gas in uscita dalla pompa percorre il condotto (1), attraversa la cartuccia disoliante (2) ed esce dalla camera (3) circostante.

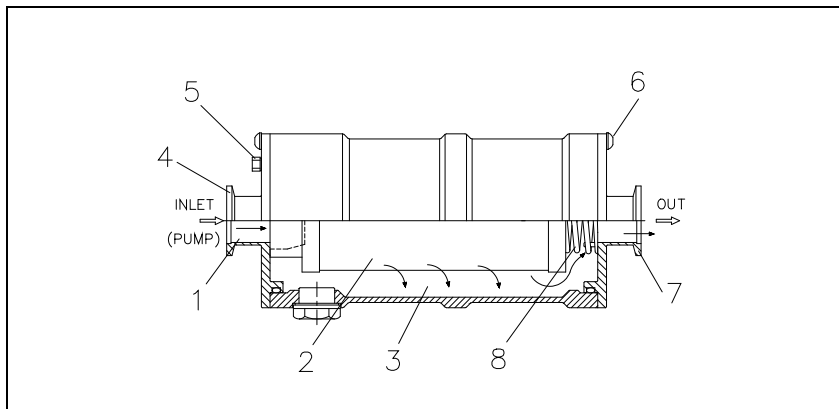

**Figura 2**

Le nebbie di olio sono trattenute dalla cartuccia, dove si aggregano sotto forma di gocce. Queste, per gravità, si depositano sul fondo del carter.

La cartuccia ha pure la capacità di trattenere particelle solide trascinate dal gas. Queste particelle sono la causa principale di intasamento della cartuccia.

Per evitare che la pressione a monte dell'elemento filtrante raggiunga valori tali da compromettere il corretto funzionamento della pompa, è previsto un dispositivo di sovrappressione che interviene quando la pressione raggiunge il valore di 1 bar.

Quando la cartuccia è intasata ed il sistema di sicurezza si è innescato, le nebbie di olio vengono trascinate dal flusso dei gas direttamente dalla pompa all'ambiente esterno.

E' buona norma, prima di giungere al completo intasamento della cartuccia, sostituire la cartuccia a intervalli di tempo regolari, dipendenti dal tipo di applicazione della pompa.

## Installazione del filtro disoliatore

Il filtro disoliatore si monta sulla pompa unendo la flangia (4) (vedere la figura precedente) mediante collare di serraggio e anello di centraggio alla flangia di scarico della pompa.

Il filtro viene fornito montato come mostrato in figura.

## Manutenzione

### Drenaggio dell'Olio

L'olio che si accumula nel carter deve essere rimosso prima che bagni la superficie esterna della cartuccia disoliante e ne riduca l'efficienza.

L'oblò posto su un lato del carter consente di tenere sotto controllo il livello dell'olio.

Per effettuare l'operazione di drenaggio occorre svitare il tappo (5).

### Cambio della Cartuccia

La cartuccia disoliante ha un tempo limitato di vita, che dipende dal tipo di applicazione. L'intasamento della cartuccia fa entrare in funzione il dispositivo di by-pass che invia i gas direttamente dalla pompa all'ambiente esterno prima che raggiungano pericolose sovrappressioni per la pompa.

In questo caso i fumi d'olio si diffondono nell'ambiente esterno indicando l'avvenuto intasamento della cartuccia stessa e, per evitare l'inquinamento dell'ambiente, si consiglia di sostituire la cartuccia.

## 1 Istruzioni per l'uso

### Parti di ricambio ed accessori

Per sostituire la cartuccia occorre seguire i seguenti passi:

1. Svitare le quattro viti (6).
- 

#### **AVVERTENZA!**



**Avere l'accortezza di trattenere i due elementi collegati affinché questi non vengano scagliati via a causa della compressione della molla.**

---

2. Rimuovere la cartuccia (2) e sostituirla con quella di ricambio.
3. Accostare la testata (7) al tubo facendo attenzione che la molla (8) non esca dal proprio alloggiamento e che prema la cartuccia contro la sua sede.
4. Avvitare le quattro viti (6).

## Parti di ricambio ed accessori

Per avere le giuste parti di ricambio, occorre indicare nell'ordine il tipo di filtro ed il suo numero di modello (indicato sulla sua etichetta).

Come ricambio è disponibile un kit che contiene le guarnizioni del filtro ed il filtro stesso, con la seguente denominazione:

- DS Exhaust Filter Kit NW 25 (P/N 949-9342)

## Smaltimento

### Significato del logo "WEEE" presente sulle etichette

Il simbolo qui sotto riportato applicato in ottemperanza alla direttiva CE denominata "WEEE".

Questo simbolo (**valido solo per i paesi della Comunità Europea**) indica che il prodotto sul quale è applicato, **NON** deve essere smaltito insieme ai comuni rifiuti domestici o industriali, ma deve essere avviato ad un sistema di raccolta differenziata.

Si invita pertanto l'utente finale a contattare il fornitore del dispositivo, sia esso la casa madre o un rivenditore, per avviare il processo di raccolta e smaltimento, dopo opportuna verifica dei termini e condizioni contrattuali di vendita.

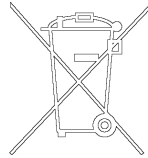

# 1 Istruzioni per l'uso

## Smaltimento

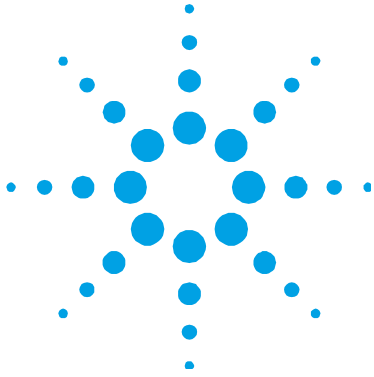

## 2 Instructions for Use

Description of the Exhaust Filter	16
Technical Specification	16
Outline Drawing	17
Operation	18
Exhaust Filter Installation	19
Maintenance	19
Oil Drainage	19
Cartridge Changing	19
Replacement Parts and Accessories	20
Disposal	21



[WWW.JEVINSTRUMENTS.COM](http://WWW.JEVINSTRUMENTS.COM)



Original Instructions



## Description of the Exhaust Filter

The oil Exhaust Filter NW25 uses high efficiency oil separating cartridge.

Its function is to purify the exhaust gas from oil or other liquid aerosol.

**WARNING!**



**Gases and vapors are not filtered, so toxic gases from the pump must be disposed according to the general disposition about toxic gases.**

## Technical Specification

The following table details the main technical specifications of the Exhaust Filter.

**Tab. 1**

	DS NW25
Max. flux at 1 bar and 20 °C [Nm <sup>3</sup> /h]	90
Pressure drop [mbar]	150
Maximum allowed pressure [bar]	1.0
Inlet/outlet flange	25 KF
Applicable pumps	DS 102 / 202 / 302 / 402 / 602





## Outline Drawing

The following figure shows the outline drawing for the Exhaust Filter (the dimensions are inches [mm]).

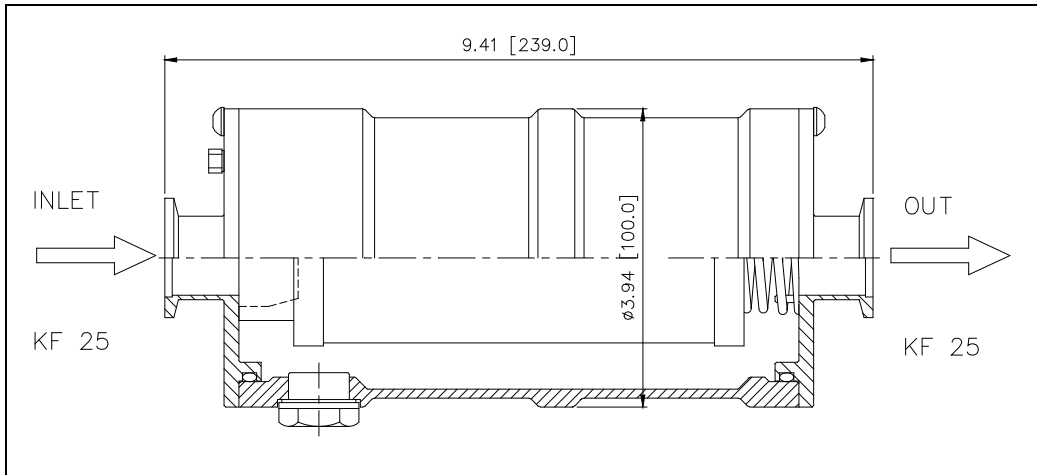

Figure 1 Model 949-9392



WWW.JEVINSTRUMENTS.COM



## Operation

For the following description refer to the following figure.

The output gas from the pump flows through the duct (1), passes the cartridge (2) and exits from the surrounding chamber (3).

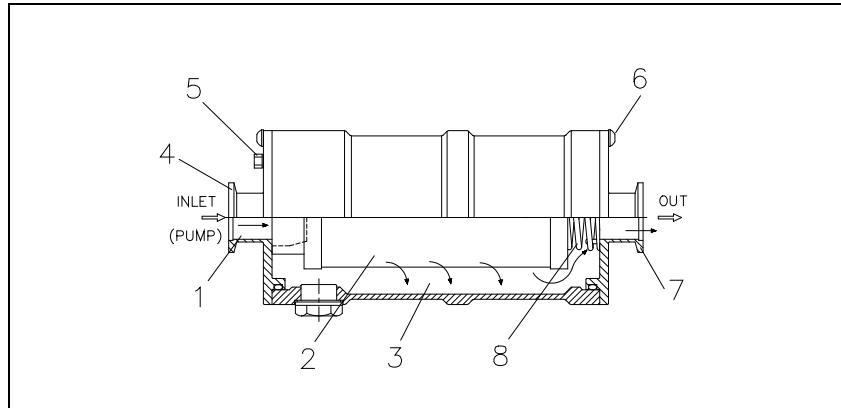

**Figure 2**

The oil mist is filtered by the cartridge where it transforms into drops. The drops deposit on the carter bottom for the gravity effect.

The cartridge also filters the solid particles from the gas. These particles are the main cause of the cartridge clog.

To avoid that the pressure before the filtering element increases so that the pump does not work properly, an overpressure device is provided that intervenes when the pressure reaches the 1 bar value.

When the cartridge is obstructed and the security system is operating, the oil mist is dragged by the gas flux from the pump directly to the external ambient.

Before the cartridge is completely obstructed, it is advisable to change it on a regular basis according to the pump application.



## Exhaust Filter Installation

The Exhaust Filter is installed on the pump connecting the flange (4) (see the preceding figure) to the outlet flange of the pump by means of a clamping collar and centering ring.

The filter is factory assembled as shown in the figure.

## Maintenance

### Oil Drainage

The oil on the carter bottom must be periodically removed before it reaches the external surface of the cartridge so that its efficiency is reduced. The window on a side of the carter allows to check the oil level. To drain the oil it is necessary to unscrew the plug (5).

### Cartridge Changing

The cartridge has a limited life time that depends on the pump application. The cartridge clogging activates the by-pass device so that the gases from the pump are directly sent to the external ambient to avoid dangerous pump overpressures.

In this case the oil mist are diffused into the atmosphere indicating that the cartridge is obstructed and, to avoid the ambient pollution, it is advisable to change the cartridge.



WWW.JEVINSTRUMENTS.COM



## 2 Instructions for Use

### Replacement Parts and Accessories

To change the cartridge you must execute the following steps:

1. Unscrew the four screws (6).
- 

#### **WARNING!**



**Take care to keep in position the two elements so that they are not thrown away by the spring compression.**

---

2. Remove the cartridge (2) and insert the new one.
3. Place the head (7) close to the pipe taking care that the spring (8) do not exit from its seat and that it presses the cartridge in its position.
4. Screw the four screws (6).

## Replacement Parts and Accessories

To obtain the correct replacement parts, the order must contain the filter type and its model number (it is indicated onto the filter label)

As replacement parts ordering, a filter kit, that contains the filter itself and the relevant gaskets, is available, with the following description:

- DS Exhaust Filter Kit NW 25 (P/N 949-9342)



[WWW.JEVINSTRUMENTS.COM](http://WWW.JEVINSTRUMENTS.COM)



## Disposal

**Meaning of the "WEEE" logo found in labels.** The following symbol is applied in accordance with the EC WEEE (Waste Electrical and Electronic Equipment) Directive. This symbol (**valid only in countries of the European Community**) indicates that the product it applies to must NOT be disposed of together with ordinary domestic or industrial waste but must be sent to a differentiated waste collection system. The end user is therefore invited to contact the supplier of the device, whether the Parent Company or a retailer, to initiate the collection and disposal process after checking the contractual terms and conditions of sale.

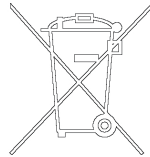

[WWW.JEVINSTRUMENTS.COM](http://WWW.JEVINSTRUMENTS.COM)



## 2 Instructions for Use Disposal



[WWW.JEVINSTRUMENTS.COM](http://WWW.JEVINSTRUMENTS.COM)





**Agilent Technologies**

***Vacuum Products Division***

*Dear Customer,*

*Thank you for purchasing an Agilent vacuum product. At Agilent Vacuum Products Division we make every effort to ensure that you will be satisfied with the product and/or service you have purchased.*

*As part of our Continuous Improvement effort, we ask that you report to us any problem you may have had with the purchase or operation of our products. On the back side you find a Corrective Action request form that you may fill out in the first part and return to us.*

*This form is intended to supplement normal lines of communications and to resolve problems that existing systems are not addressing in an adequate or timely manner.*

*Upon receipt of your Corrective Action Request we will determine the Root Cause of the problem and take the necessary actions to eliminate it. You will be contacted by one of our employees who will review the problem with you and update you, with the second part of the same form, on our actions.*

*Your business is very important to us. Please, take the time and let us know how we can improve.*

*Sincerely,*

**Giampaolo LEVI**

***Vice President and General Manager  
Agilent Vacuum Products Division***

**Note:** Fax or mail the Customer Request for Action (see backside page) to Agilent Vacuum Products Division (Torino) – Quality Assurance or to your nearest Agilent representative for onward transmission to the same address.

**CUSTOMER REQUEST FOR CORRECTIVE / PREVENTIVE / IMPROVEMENT ACTION**

TO: AGILENT VACUUM PRODUCTS DIVISION TORINO – QUALITY ASSURANCE

FAX N°: XXXX-011-9979350

ADDRESS: AGILENT TECHNOLOGIES ITALIA S.p.A. – Vacuum Products Division –

Via F.lli Varian, 54 – 10040 Leinì (TO) – Italy

E-MAIL: [vpd-qualityassurance\\_pdl-ext@agilent.com](mailto:vpd-qualityassurance_pdl-ext@agilent.com)

NAME	COMPANY	FUNCTION
ADDRESS:		
TEL. N° : _____ FAX N° : _____		
E-MAIL: _____		
PROBLEM / SUGGESTION :		
REFERENCE INFORMATION (model n°, serial n°, ordering information, time to failure after installation, etc.):		
CORRECTIVE ACTION PLAN / ACTUATION (by AGILENT VPD)		DATE _____ LOG N° _____

XXX = Code for dialing Italy from your country (es. 01139 from USA; 00139 from Japan, etc.)







**Vacuum Products Division  
Instructions for returning products**

Dear Customer:

Please follow these instructions whenever one of our products needs to be returned.

- 1) Complete the attached Request for Return form and send it to Agilent Technologies (see below), taking particular care to identify all products that have pumped or been exposed to any toxic or hazardous materials.
- 2) After evaluating the information, Agilent Technologies will provide you with a Return Authorization (RA) number via email or fax, as requested.  
**Note:** Depending on the type of return, a Purchase Order may be required at the time the Request for Return is submitted. We will quote any necessary services (evaluation, repair, special cleaning, eg).
- 3) **Important steps for the shipment of returning product:**
  - Remove all accessories from the core product (e.g. inlet screens, vent valves).
  - Prior to shipment, drain any oils or other liquids, purge or flush all gasses, and wipe off any excess residue.
  - If ordering an Advance Exchange product, please use the packaging from the Advance Exchange to return the defective product.
  - Seal the product in a plastic bag, and package product carefully to avoid damage in transit. You are responsible for loss or damage in transit.
  - Agilent Technologies is not responsible for returning customer provided packaging or containers.
  - **Clearly label package with RA number.** Using the shipping label provided will ensure the proper address and RA number are on the package. Packages shipped to Agilent without a RA clearly written on the outside cannot be accepted and will be returned.
- 4) Return only products for which the RA was issued.
- 5) **Product being returned under a RA must be received within 15 business days.**
- 6) **Ship to the location specified on the printable label, which will be sent, along with the RA number, as soon as we have received all of the required information.** Customer is responsible for freight charges on returning product.
- 7) Return shipments must comply with all applicable **Shipping Regulations** (IATA, DOT, etc.) and carrier requirements.

RETURN THE COMPLETED REQUEST FOR RETURN FORM TO YOUR NEAREST LOCATION:

**EUROPE:**  
Fax: 00 39 011 9979 330  
Fax Free: 00 800 345 345 00  
Toll Free: 00 800 234 234 00  
[vpt-customer@agilent.com](mailto:vpt-customer@agilent.com)

**NORTH AMERICA:**  
Fax: 1 781 860 9252  
Toll Free: 800 882 7426, Option 3  
[vpl-ra@agilent.com](mailto:vpl-ra@agilent.com)

**PACIFIC RIM:**  
please visit our website for individual office information  
<http://www.agilent.com>



Please read important policy information on Page 3 that applies to all returns.

1) CUSTOMER INFORMATION

Form with fields for Company Name, Contact Name, Tel, Email, Fax, Customer Ship To, Customer Bill To, and VAT reg. Number.

2) PRODUCT IDENTIFICATION

Table with 4 columns: Product Description, Agilent P/N, Agilent S/N, Original Purchasing Reference.

3) TYPE OF RETURN (Choose one from each row and supply Purchase Order if requesting a billable service)

- 3A. [ ] Non-Billable [ ] Billable -> New PO # (hard copy must be submitted with this form):
3B. [ ] Exchange [ ] Repair [ ] Upgrade [ ] Consignment/Demo [ ] Calibration [ ] Evaluation [ ] Return for Credit

4) HEALTH and SAFETY CERTIFICATION

AGILENT TECHNOLOGIES CANNOT ACCEPT ANY PRODUCTS CONTAMINATED WITH BIOLOGICAL OR EXPLOSIVE HAZARDS, RADIOACTIVE MATERIAL, OR MERCURY AT ITS FACILITY. Call Agilent Technologies to discuss alternatives if this requirement presents a problem. The equipment listed above (check one): [ ] HAS NOT pumped or been exposed to any toxic or hazardous materials. OR [ ] HAS pumped or been exposed to the following toxic or hazardous materials. If this box is checked, the following information must also be filled out. Check boxes for all materials to which product(s) pumped or was exposed: [ ] Toxic [ ] Corrosive [ ] Reactive [ ] Flammable [ ] Explosive [ ] Biological [ ] Radioactive. List all toxic/hazardous materials. Include product name, chemical name, and chemical symbol or formula: NOTE: If a product is received at Agilent which is contaminated with a toxic or hazardous material that was not disclosed, the customer will be held responsible for all costs incurred to ensure the safe handling of the product, and is liable for any harm or injury to Agilent employees as well as to any third party occurring as a result of exposure to toxic or hazardous materials present in the product. Print Name: Authorized Signature: Date:

5) FAILURE INFORMATION:

Failure Mode (REQUIRED FIELD. See next page for suggestions of failure terms):
Detailed Description of Malfunction: (Please provide the error message)
Application (system and model):

I understand and agree to the terms of Section 6, Page 3/3.
Print Name: Authorized Signature: Date:



Vacuum Products Division
Request for Return Form
(Health and Safety Certification)

Please use these Failure Mode to describe the concern about the product on Page 2.

TURBO PUMPS and TURBO CONTROLLERS

Table with 3 columns: APPARENT DEFECT/MALFUNCTION, POSITION, and PARAMETERS. Includes sub-headers like 'Does not start', 'Noise', 'Vertical', 'Horizontal', etc.

ION PUMPS/CONTROLLERS

Table with 2 columns listing defects: Bad feedthrough, Vacuum leak, Error code on display, Poor vacuum, High voltage problem, Other.

VALVES/COMPONENTS

Table with 2 columns listing defects: Main seal leak, Solenoid failure, Damaged sealing area, Bellows leak, Damaged flange, Other.

LEAK DETECTORS

Table with 2 columns listing defects: Cannot calibrate, Vacuum system unstable, Failed to start, No zero/high background, Cannot reach test mode, Other.

INSTRUMENTS

Table with 2 columns listing defects: Gauge tube not working, Communication failure, Error code on display, Display problem, Degas not working, Other.

SCROLL AND ROTARY VANE PUMPS

Table with 2 columns listing defects: Pump doesn't start, Doesn't reach vacuum, Pump seized, Noisy pump (describe), Over temperature, Other.

DIFFUSION PUMPS

Table with 2 columns listing defects: Heater failure, Doesn't reach vacuum, Vacuum leak, Electrical problem, Cooling coil damage, Other.

Section 6) ADDITIONAL TERMS

Please read the terms and conditions below as they apply to all returns and are in addition to the Agilent Technologies Vacuum Product Division – Products and Services Terms of Sale.

- Customer is responsible for the freight charges for the returning product. Return shipments must comply with all applicable Shipping Regulations (IATA, DOT, etc.) and carrier requirements.
Customers receiving an Advance Exchange product agree to return the defective, rebuildable part to Agilent Technologies within 15 business days. Failure to do so, or returning a non-rebuildable part (crashed), will result in an invoice for the non-returned/non-rebuildable part.
Returns for credit toward the purchase of new or refurbished Products are subject to prior Agilent approval and may incur a restocking fee. Please reference the original purchase order number.
Units returned for evaluation will be evaluated, and a quote for repair will be issued. If you choose to have the unit repaired, the cost of the evaluation will be deducted from the final repair pricing. A Purchase Order for the final repair price should be issued within 3 weeks of quotation date. Units without a Purchase Order for repair will be returned to the customer, and the evaluation fee will be invoiced.
A Special Cleaning fee will apply to all exposed products per Section 4 of this document.
If requesting a calibration service, units must be functionally capable of being calibrated.

## Sales and Service Offices

### United States

**Agilent Technologies**  
**Vacuum Products Division**  
121 Hartwell Avenue  
Lexington, MA 02421 - USA  
Tel.: +1 781 861 7200  
Fax: +1 781 860 5437  
Toll-Free: +1 800 882 7426

### Benelux

**Agilent Technologies Netherlands B.V.**  
**Vacuum Products Division**  
Herculesweg 8  
4338 PL Middelburg  
The Netherlands  
Tel.: +31 118 671570  
Fax: +31 118 671569  
Toll-Free: 00 800 234 234 00

### Canada

**Central coordination through: Agilent Technologies**  
**Vacuum Products Division**  
121 Hartwell Avenue  
Lexington, MA 02421 - USA  
Tel.: +1 781 861 7200  
Fax: +1 781 860 5437  
Toll-Free: +1 800 882 7426

### China

**Agilent Technologies (China) Co. Ltd**  
**Vacuum Products Division**  
No.3, Wang Jing Bei Lu,  
Chao Yang District,  
Beijing, 100102  
China  
Tel.: +86 (10) 6439 7718  
Toll-Free: 800 820 6556

### France

**Agilent Technologies France**  
**Vacuum Products Division**  
7 Avenue des Tropiques  
Z.A. de Courtaboeuf - B.P. 12  
91941 Les Ulis cedex - France  
Tel.: +33 (0) 1 69 86 38 84  
Fax: +33 (0) 1 69 86 29 88  
Toll free: 00 800 234 234 00

### Germany and Austria

**Agilent Technologies**  
**Vacuum Products Division** Alsfelder Strasse 6 Postfach 11  
14 35  
64289 Darmstadt – Germany  
Tel.: +49 (0) 6151 703 353  
Fax: +49 (0) 6151 703 302  
Toll free: 00 800 234 234 00

### India

**Agilent Technologies India Pvt. Ltd.**  
**Vacuum Product Division**  
G01. Prime corporate Park,  
230/231, Sahar Road, Opp. Blue Dart Centre,  
Andheri (East), Mumbai – 400 099.India  
Tel: +91 22 30648287/8200  
Fax: +91 22 30648250  
Toll Free: 1800 113037

### Italy

**Agilent Technologies Italia S.p.A.**  
**Vacuum Products Division**  
Via F.lli Varian 54  
10040 Leini, (Torino) - Italy  
Tel.: +39 011 997 9111 Fax: +39 011 997 9350  
Toll-Free: 00 800 234 234 00

### Japan

**Agilent Technologies Japan, Ltd.**  
**Vacuum Products Division**  
8th Floor Sumitomo Shibaura Building  
4-16-36 Shibaura Minato-ku Tokyo 108-0023 - Japan  
Tel.: +81 3 5232 1253  
Fax: +81 3 5232 1710  
Toll-Free: 0120 655 040

### Korea

**Agilent Technologies Korea, Ltd.**  
**Vacuum Products Division**  
Shinsa 2nd Bldg. 2F 966-5 Daechi-dong  
Kangnam-gu, Seoul  
Korea 135-280  
Tel.: +82 2 3452 2452  
Fax: +82 2 3452 2451  
Toll-Free: 080 222 2452

### Mexico

**Agilent Technologies**  
**Vacuum Products Division**  
Concepcion Beistegui No 109 Col Del Valle  
C.P. 03100 – Mexico, D.F.  
Tel.: +52 5 523 9465  
Fax: +52 5 523 9472

### Singapore

**Agilent Technologies Singapore Pte. Ltd.**  
**Vacuum Products Division**  
Agilent Technologies Building,  
1 Yishun Avenue 7,  
Singapore 768923  
Tel : (65) 6215 8045  
Fax : (65) 6754 0574

### Southeast Asia

**Agilent Technologies Sales Sdn Bhd**  
**Vacuum Products Division**  
Unit 201, Level 2 uptown 2,  
2 Jalan SS21/37, Damansara Uptown  
47400 Petaling Jaya,  
Selangor, Malaysia  
Tel : +603 7712 6106  
Fax: +603 6733 8121

### Taiwan

**Agilent Technologies Taiwan Limited**  
**Vacuum Products Division (3F)**  
20 Kao-Shuang Rd.,  
Pin-Chen City, 324  
Taoyuan Hsien , Taiwan, R.O.C.  
Tel. +886 34959281  
Toll Free: 0800 051 342

### UK and Ireland

**Agilent Technologies UK, Ltd.**  
**Vacuum Products Division**  
6 Mead Road Oxford Industrial Park  
Yarnton, Oxford OX5 1QU – UK  
Tel.: +44 (0) 1865 291570  
Fax: +44 (0) 1865 291571  
Toll free: 00 800 234 234 00

### Other Countries

**Agilent Technologies Italia S.p.A.**  
**Vacuum Products Division**  
Via F.lli Varian 54 10040 Leini, (Torino) -  
Italy  
Tel.: +39 011 997 9111  
Fax: +39 011 997 9350  
Toll-Free: 00 800 234 234 00

### Customer Support & Service

#### **NORTH AMERICA:**

Toll Free: 800 882 7426, Option 3  
vpl-ra@agilent.com

#### **EUROPE:**

Toll Free: 00 800 234 234 00  
vpt-customer@agilent.com

#### **PACIFIC RIM:**

please visit our website for individual office  
information <http://www.agilent.com>

#### **Worldwide Web Site, Catalog and Order**

#### **On-line:**

[www.agilent.com](http://www.agilent.com)  
Representative in most countries  
12/10



© Agilent Technologies, Inc. 2011

Printed in ITALY

05/2011

Publication Number: 87-900-941-01(F)



# Agilent Technologies