



Mass Spectrometers for Gas Analysis



MASS SPECTROMETERS

Systems for Gas Analysis Applications

Hidden Analytical offers a versatile range of gas analysis systems, designed for real-time, precise detection of multiple gas and vapour species, with dynamic measurement capabilities from ppb levels to 100% concentration.

With over 40 years of expertise, Hidden Analytical is renowned for designing and developing top-quality quadrupole mass spectrometer-based systems. Our instruments are recognised for their superior sensitivity, accuracy, and reproducibility, supported by a global service and applications network that ensures exceptional customer support.

Our gas analysis systems are capable of analysing an extensive array of gases and vapours, including ammonia, argon, carbon dioxide, methane, nitrogen, oxygen, volatile organic compounds (VOCs), and many more.

Recent advancements in quadrupole mass spectrometry, such as our controllable field axis technology, offer enhanced capabilities:

- ▶ **Soft Ionisation:** Simplifies the analysis of complex spectra with precise ion source control, enabling accurate electron energy adjustment from 0.4 eV to 150 eV.
- ▶ **High Abundance Sensitivity:** Triple-filter technology minimises peak tailing for improved sensitivity and accuracy.



Contents

Gas Analysis Systems



QGA 2.0 - Quantitative Gas Analyser

QGA 2.0 – Quantitative Gas Analyser

HPR-20 EGA – Gas Analysis System for Evolved Gas Analysis in TGA-MS

HPR-20 R&D – Gas Analysis System for Advanced Research

HPR-20 TMS – Transient MS for Fast Event Gas Analysis

SYSTEMS FOR SPECIALIST APPLICATIONS – HPR-20 DLS, HPR-20 EPIC, HPR-20 S1000

PRESSURE AND TEMPERATURE GAS SAMPLING OPTIONS

HPR-20 MULTI-STREAM SYSTEMS – Gas Analysis Systems for Multi-stream Analysis

HPR-40 DSA & pQA – for Dissolved Species Analysis

HPR-20 OEMS – for Continuous Analysis of Evolved Gases and Vapours in Electrochemistry

HPR-40 DEMS – for Differential Electrochemical Mass Spectrometry

HPR-60 MBMS – Molecular Beam Sampling Mass Spectrometer for Ion and Radical Analysis

HPR-70 – Batch Inlet Gas Analysis System for Discrete Low Volume Sample Analysis

LAS LEAK ANALYSIS SYSTEM – Automated Battery Leak Testing



HPR-20 EGA - Gas Analysis System for Evolved Gas Analysis in TGA-MS

Software

QGA 2 SOFTWARE – for Quantitative Gas and Vapour Analysis

EGAsoft SOFTWARE – for Evolved Gas Analysis

MASsoft PROFESSIONAL SOFTWARE – Control Software



HPR-40 DEMS

QGA 2.0

Quantitative Gas Analyser

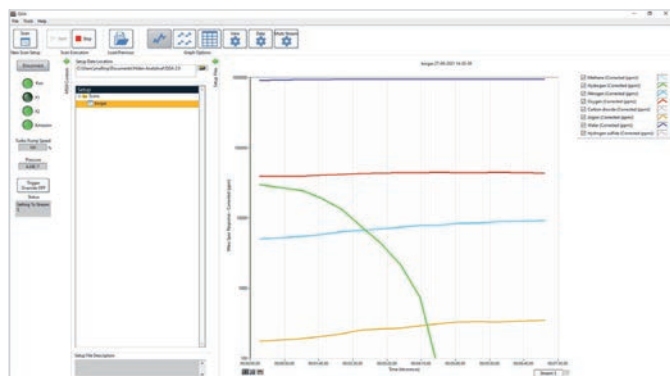

QGA 2 Software Homescreen

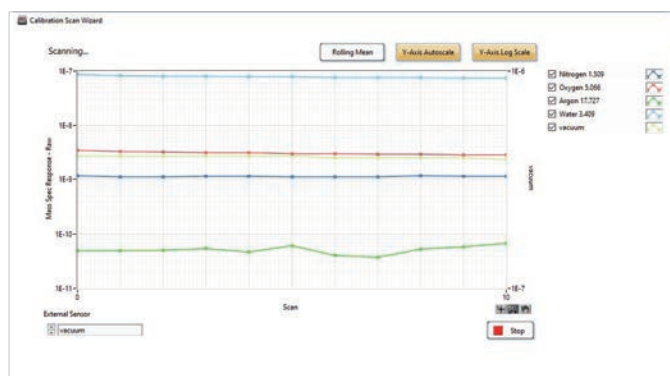

QGA 2 Software Calibration

The QGA 2.0 is a full update of our popular QGA system, incorporating significant enhancements for improved performance and ease of use. The QGA 2.0 is lighter, more user-friendly, environmentally considerate, and packed with powerful features.

With a compact design that reduces both its footprint and weight, this advanced model has been optimized for continuous analysis of gases and vapours in near atmospheric pressures. To suit diverse research demands, a range of inlet accessories are available, configurations are available for sampling from ambient to pressures as high as 30 bar.

The Hiden QIC (Quartz Inert Capillary) sampling interface sampling from 100 mbar to 2 bar is included as standard. Operating to 200°C, the QIC flexible 2 m capillary inlet provides fast response times of less than 300 milliseconds for most common gases and vapours, including water and organic vapours.

The QGA 2.0 system has a mass range of 200 amu (300 amu option) and a detection capability from 100% to less than 100 parts-per-billion.

The QGA 2.0 system connects to a range of backing pump options including a high-performance scroll pump. For flexibility the QGA will operate with foreline connection up to 10 m.

FEATURES:

- ▶ Lightweight - 22% lighter
- ▶ Compact - 42% smaller footprint
- ▶ Sustainable - uses fewer materials in construction
- ▶ Simplified - 1-button start-up
- ▶ Versatile - compatible with a selection of inlets
- ▶ Optimised - for hydrogen analysis
- ▶ Advanced - new electronics package
- ▶ Speed - up to 1000 measurements per second
- ▶ Intuitive - QGA 2 software package

QGA 2.0 - Quantitative Gas Analyser



HPR-20 EGA

for Evolved Gas Analysis in TGA-MS



HPR-20 EGA

The Hiden HPR-20 EGA gas analysis system is configured for continuous analysis of evolved gases and vapours from thermogravimetric analysers (TGA). Interface systems are available for most TGA instruments. The TGA interface includes re-entrant furnace sampling, providing close coupling to the TGA furnace region for optimized evolved gas/vapour analysis.

Custom designed interfaces are available for special requirements with alternative systems being offered for applications requiring direct sampling from advanced thermogravimetric analysers operating at pressures up to 30 bar.

Fast response, low dead volume interfaces are offered for the most popular TGA equipment.

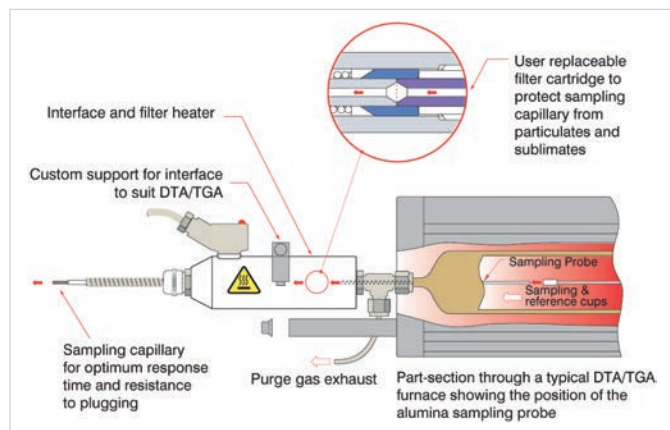

Typical TGA inlet

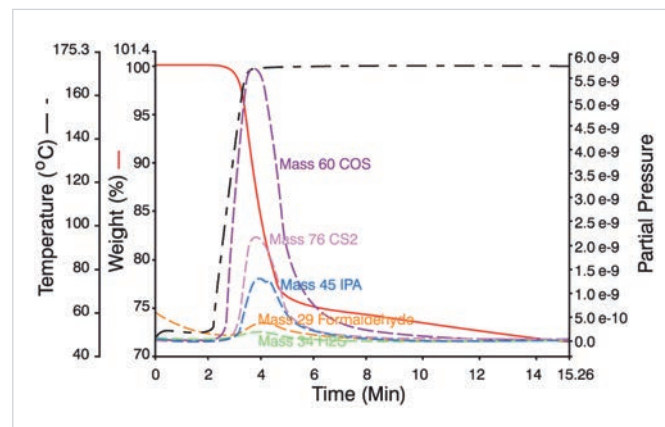

TGA-MS plot

FEATURES:

- ▶ Enhanced pumping for light gases
- ▶ Heated inlet for non-tailing response to desorbed gases and vapours
- ▶ Control of ionisation energy parameters for simplification of cracking patterns
- ▶ Custom, low dead volume interface to specific manufacturers' TGA systems
- ▶ Optimised data acquisition using EGAssoft
- ▶ Mass range option 200 or 300 amu

Each interface has been custom engineered in collaboration with TGA manufacturers and includes, where necessary, robust clamping arrangements and an in-line heated filter assembly between the outlet of the TGA and the MS capillary inlet.

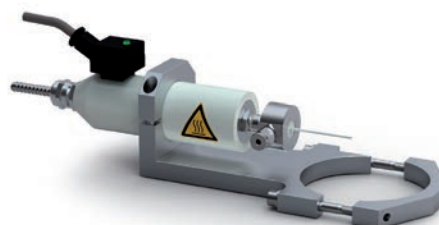

HPR-20 R&D

for Advanced Research

The Hiden HPR-20 R&D specialist gas analysis system is a benchtop mass spectrometer for the monitoring of evolved gases and vapours. A triple filter mass spectrometer is included providing improved resolution and abundance sensitivity with an ultimate detection limit of 5 ppb subject to spectral interference.

The HPR-20 R&D is offered with a wide range of interfaces for connection to external equipment and is configured with Hiden's heated Quartz Inert Capillary (QIC) for continuous sampling of gases and vapours.

Backing and bypass pumping is provided by a high performance scroll pump. Gas sampling is continuous with a gas sample flow rate user configurable in the range < 1 ml/min to > 15 ml/min.



HPR-20 R&D

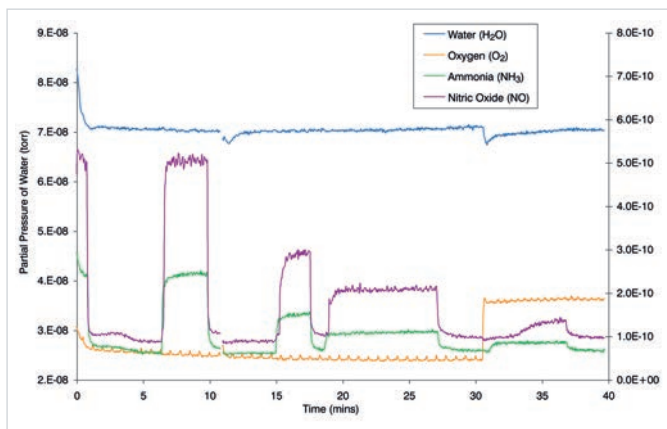

Simultaneous measurement of low ppm levels of ammonia, nitric oxide and oxygen in percentage (2%) concentrations of water. Primary Axis represents Partial Pressure of Water (H₂O). Secondary Axis represents Partial Pressure of Oxygen (O₂), Ammonia (NH₃) and Nitric Oxide (NO)

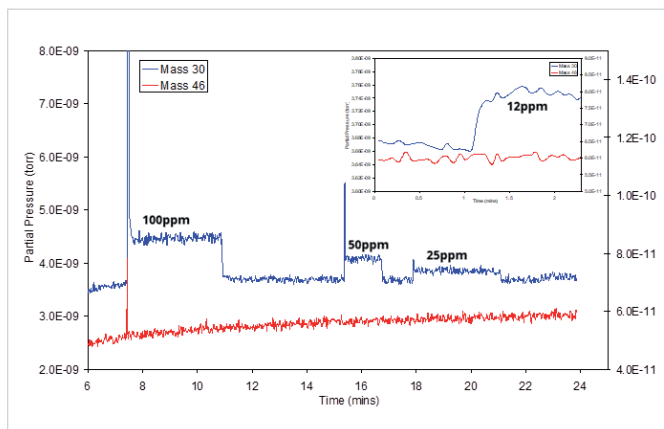

Detection Limit of NO in 1000 ppm NO₂ (Inset: Expansion of detection of 12 ppm NO in 1000 ppm NO₂). Primary Axis represents Partial Pressure at m/z 30, Secondary Axis represents Partial Pressure at m/z 46

FEATURES:

- ▶ Triple filter mass spectrometer
- ▶ Mass range options: 200, 300 or 510 amu
- ▶ Enhanced abundance sensitivity
- ▶ Detection to 5 ppb
- ▶ APSI-MS soft ionisation mode

HPR-20 TMS

Transient MS for Fast Event Gas Analysis



HPR-20 TMS transient MS QIC inlet

The Hiden HPR-20 TMS Transient MS is configured for fast event analysis of gases and vapours at pressures near atmosphere. Ideal for fast gas switching experiments, the MS features the Hiden QIC quartz-lined 0.9 m sampling interface. The inlet, operating at 200°C, provides response times of less than 150 ms to changes in gas composition with a 5 decade response time in < 100 ms.

The QIC inlet is coupled directly to Hiden's Pulse Ion Counting (PIC) digital MS which is capable of measurement speeds of up to 1000 data points/s over the entire 7 decade dynamic range.

Suited to fast data acquisition in the measurement of gas and vapour compositions in the sub ppm to low % concentration range.

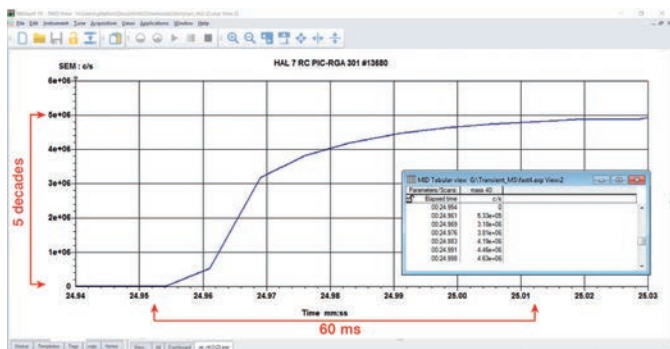

HPR-20 transient MS data: > 5 decades response in < 100 ms

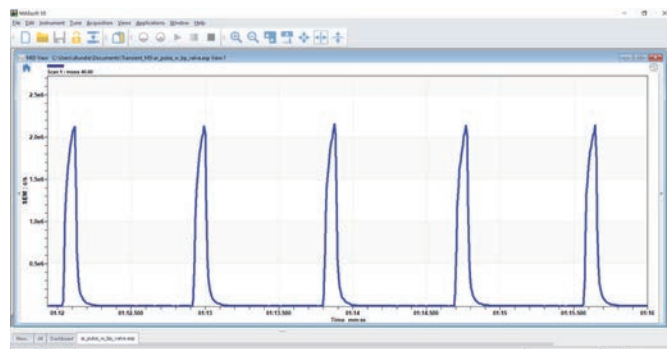

Analysis of fast gas pulsing experiments

FEATURES:

- ▶ 0.9 m fast response QIC capillary - 150 ms response time
- ▶ Open ion source and optimised pumping configuration for fast response
- ▶ Digital PIC detector - 7 decades continuous dynamic range
- ▶ Detection of low ppm to high % levels in < 100 ms
- ▶ Fast scan speeds, 1000 data points/s for transient analysis

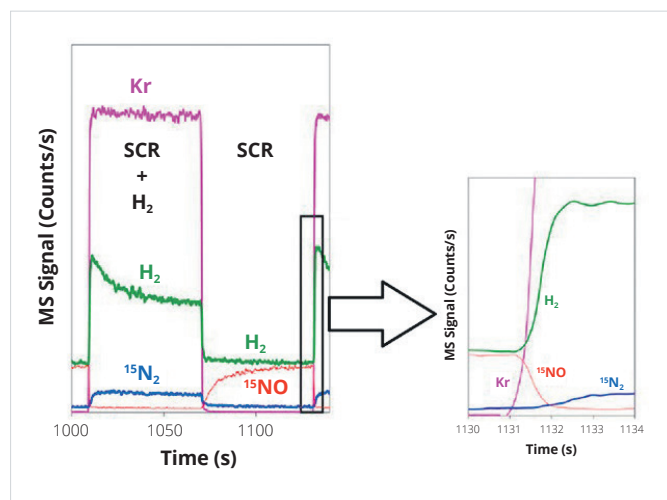

Mass spectrometer response for $^{15}\text{N}_2$, ^{15}NO , H_2 and Kr when switching 0.72% H_2 in and out of a SCR (NO_x with octane) feed stream over a catalyst at 300 °C (J. P. Breen, R. Burch, C. Hardacre, C. J. Hill and C. Rioche, J. Catal., 2007, 246, 1-9).



JEVINSTRUMENTS.COM

HPR-20 RANGE

for Specialist Applications

The specialist range of Hiden HPR-20 gas analysis systems are configured for continuous analysis of gases and vapours at pressures near atmosphere in standard form, with alternative inlet systems being offered for applications requiring direct sampling from higher pressures to 30 bar.

The Hiden QIC quartz-lined sampling interface operating at 200°C provides fast response times of less than 300 milliseconds for most common gases and vapours, including water vapour.



HPR-20 DLS

HPR-20 DLS

for Ultra-High Resolution & Sensitivity Analysis of Hydrogen Isotopes and Light Gases

The HPR-20 DLS includes Hiden's DLS-20 triple filter quadrupole mass spectrometer with 20 mm pole diameter.

The DLS-20 includes unique, user switchable resolution modes allowing the DLS-20 quadrupole mass spectrometer to operate in dual quadrupole stability regions (Zones I and H) offering ultra-high resolution in the mass range to 22.5 amu (zone H) and very-high resolution performance up to 200 amu (Zone I).

HPR-20 EPIC

with Electron Impact/Electron Attachment Ionization Modes

The system includes the Hiden EPIC triple filter mass spectrometer including a high gain pulse ion counting electron multiplier detector with positive and negative ion detection. Analysis is both by standard electron impact ionization and by appearance potential soft ionisation (APSI-MS).

The system includes a software selectable mode, electron attachment mass spectrometry (EA-MS), to analyse negative ions formed within the internal ioniser by electron attachment. The electron attachment mode provides vital information for investigating electronegative species, identifying the parent molecules of stable radicals from plasma processes for example.

HPR-20 S1000

with 1000 amu mass range

The standard HPR-20 S1000 system includes the Hiden triple filter quadrupole mass spectrometer with 1000 amu mass range. The dual Faraday and pulse ion counting electron multiplier detectors allow a detection capability of less than 5 parts-per-billion.

FEATURES:

- ▶ High mass ranges
- ▶ Ultra-high resolution
- ▶ Negative ion detection with electron attachment

GAS SAMPLING INLET OPTIONS

Pressure and Temperature Gas Sampling Options

Hidden offer a variety of inlet options for the gas analysis systems. Capillary inlets are available to sample at pressures both above and below atmospheric pressure. High pressure inlets are offered for sampling gases and vapours up to 30 bar, and special capillaries are offered for low pressure sampling down to 1 mbar. There is also a high temperature version of the QIC Inlet available for demanding applications.

Other options include heated capillary extensions, heated multi-stream inlets and hot-zone adaptors for sampling from furnaces (for example TGA-MS).

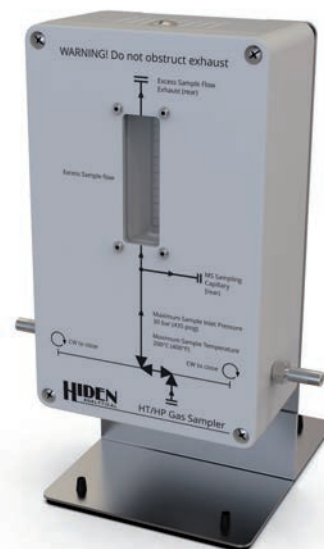

HT/HP Inlet (up to 30 bar at 200°C)

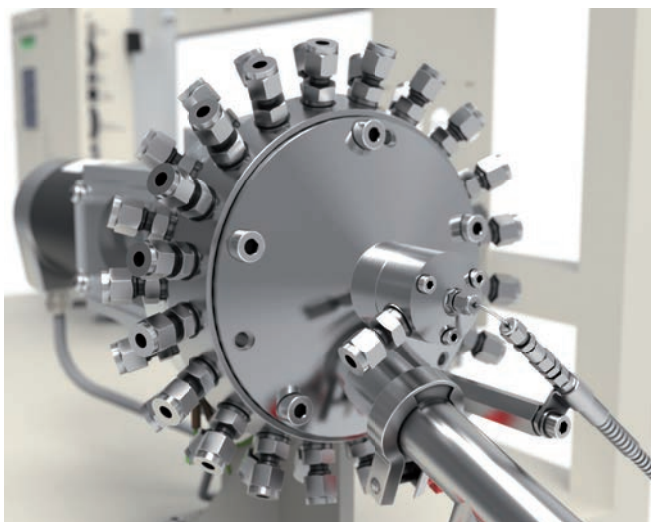

Proteus 20-way, 40-way and 80-way rotary valve



Twin Capillary QIC Inlet
- Dual Capillary system with fast switching valve



Micro-flow Capillary Inlet.
Sampling rate 12 µl/min.
Single or multi-capillary inlet option

FEATURES:

- ▶ High temperature capillary inlet
- ▶ High pressure/high temperature sampler
- ▶ Low pressure capillaries
- ▶ Micro-flow capillary inlet
- ▶ Heated capillary extension
- ▶ Hot-zone inlets
- ▶ Multi-stream selectors - 8, 16, 20, 40 and 80-way
- ▶ Flexible RGA inlet for residual gas analysis at high vacuum

HPR-20 MULTI-STREAM SYSTEMS

Gas Analysis Systems for Multi-stream Analysis

MULTI-STREAM SAMPLING CAPABILITY IS OFFERED IN TWO VERSIONS:

- ▶ Laboratory scale multi-stream valve, MSV series for analysis of up to 16 sample lines
- ▶ Process analysis multi-stream Proteus valve for sampling up to 80 sample lines

Sampling systems are configured for continuous flow for all lines as standard providing fresh sample for analysis with a minimum sample purge time. Compatible for connection with the QIC capillary inlet.

Automatic operation allows for the data to be collected and displayed stream by stream. Stream switching, data acquisition and flush timing are user controllable in software.

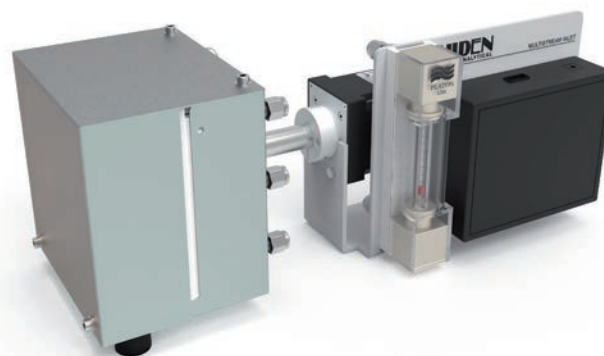
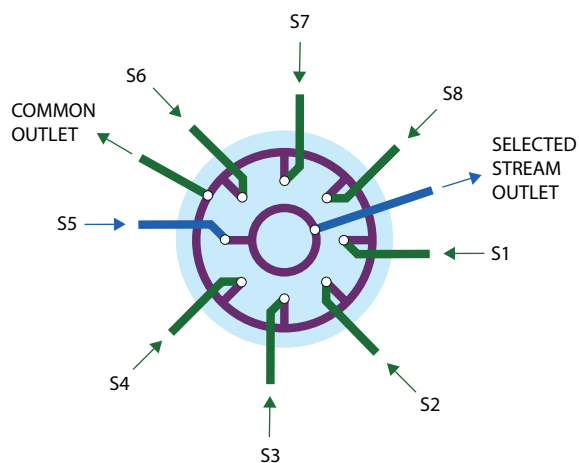

8-way multi-stream valve

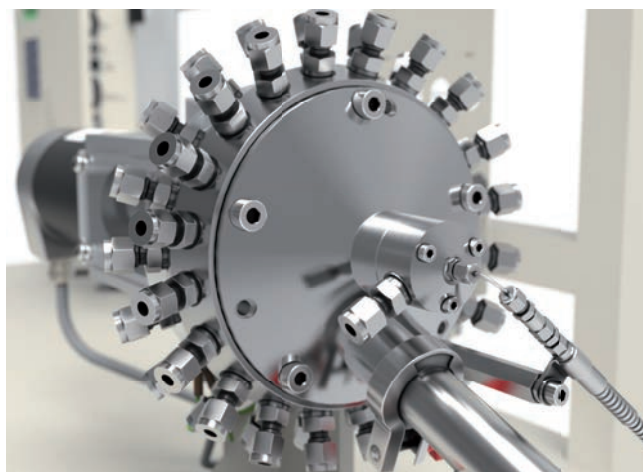

Proteus multi-stream selector

SPECIAL SYSTEM CONFIGURATIONS ARE OFFERED FOR FERMENTATION OFF-GAS ANALYSIS:

QIC BioStream systems

The QIC BioStream includes application specific process analysis software including OPC server technology, calculation of OUR (oxygen uptake rate), CER (carbon dioxide expiration rate) and RQ (respiratory quotient). Special options include an integrated selected sample stream flow meter to enable accurate analysis of the key fermentation parameters. The OPC server technology makes data transfer of the concentration of multiple gases on multiple streams together with derived parameters for each stream straightforward.



QIC BioStream-C - benchtop system



QIC BioStream system - mobile cart

HPR-40 & pQA for Dissolved Species Analysis



HPR-40 DSA

The Hiden HPR-40 DSA Membrane Inlet Mass Spectrometer (MIMS) is a compact benchtop gas analysis system for real-time quantitative analysis and monitoring of dissolved/evolved gases.

The system offers the facility for analysis to sub-ppb (parts-per-billion) levels and is suited to gas analysis applications where sample volume is small and for environmental applications where detection of a low concentration level is required. Many different interchangeable membrane inlet probes are available to address a broad range of applications.

The inlet probe uses a gas permeable membrane that allows dissolved gas/vapour molecules to pass through it and into the ion source of a high precision quadrupole mass spectrometer.

A manual isolation valve allows for control of the sampling and a solenoid safety valve provides protection for the mass spectrometer and vacuum system in case of membrane failure.



Cuvette inlet - for biofuel research



Enzyme Kinetics Probe - Real time mass spectrometry for enzyme kinetics studies



Interchangeable membrane inlet probe types



pQA

FEATURES:

- ▶ Analysis of dissolved species with mass range to 200 amu (300 amu option)
- ▶ Sub parts-per-billion detection levels
- ▶ High precision and stability species ratio measurements (e.g. marine de-nitrification studies)
- ▶ Soil core analysis
- ▶ Fermentation process analysis
- ▶ Water analysis in estuary, river or reservoir
- ▶ Groundwater contamination studies
- ▶ Methane production control
- ▶ Microbiological/enzyme activity studies
- ▶ Environmental monitoring

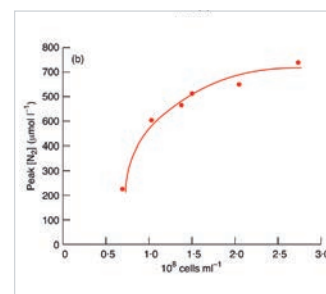
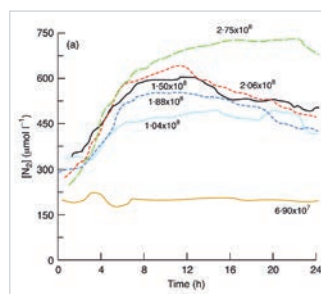

Denitrification by *Pseudomonas stutzeri* in a sterile lake water microcosm supplemented with succinate and nitrate

JR Firth and C Edwards 2000 *Journal of Applied Microbiology* **88** 853-859

HPR-20 OEMS

for Continuous Analysis of Evolved Gases and Vapours in Electrochemistry

The Hiden HPR-20 OEMS is a system configured for continuous analysis of evolved gases and vapours in electrochemistry as a function of the applied potential on the real-time scale. The ultra-low flow real time sampling capillary allows for connection for head space sampling and/or connection to electrochemical cells, EL-Cell for example.

The standard system with 200 amu mass range has a detection capability to less than 100 parts-per-billion. The optional 3F series 300 amu system with triple-stage mass filter offers extended detection levels to 5 parts-per-billion together with enhanced contamination resistance and is recommended for applications requiring optimum abundance sensitivity and/or analyses of corrosive or condensable species.



Ultra-Low Flow (ULF) QIC Heated Capillary Inlet

FEATURES:

- ▶ Response time less than 300 ms
- ▶ Detection from 100 ppb – 100%
- ▶ Fast data acquisition: up to 1000 measurements per second
- ▶ Flow rate – 12 $\mu\text{L}/\text{min}$ to 16mL/min
- ▶ APSI-MS soft ionisation mode
- ▶ Mass range: 200 amu is standard. 300 amu option
- ▶ Broad range of sampling accessories
- ▶ Custom interfaces for diverse OEMS applications

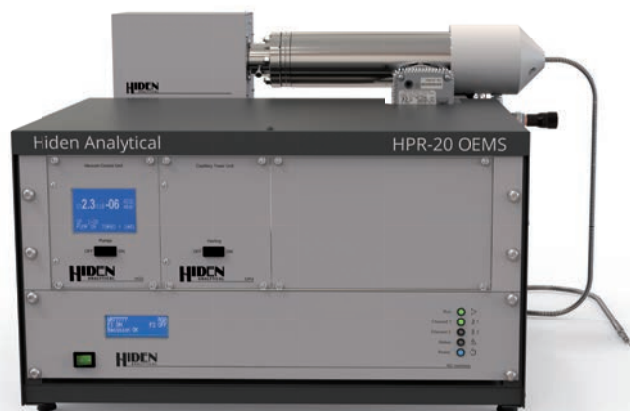

HPR-20 OEMS system

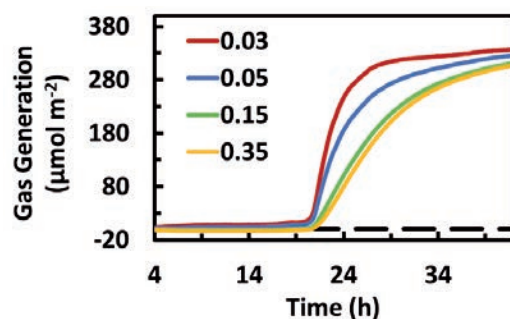

Figure 1. In-situ OEMS data plotted with gas generation from closed-cell measurements of a lithium | LNO half-cell.

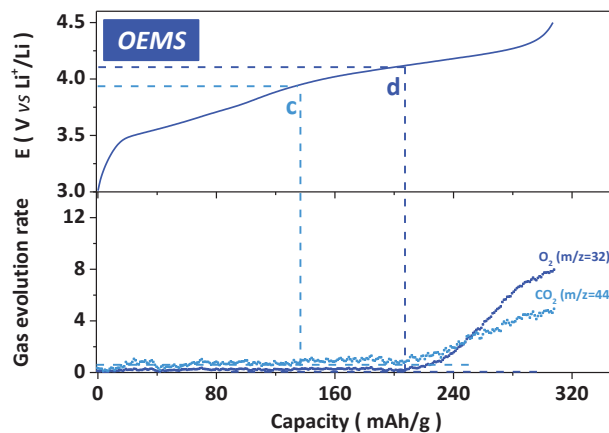

Figure 2. Potential (top panel) and gas evolution rate (bottom panel) as a function of capacity for $\text{Li}_2\text{Ru}_{0.75}\text{Ti}_{0.25}\text{O}_3$ measured by OEMS.

Reference: *Journal of The Electrochemical Society* (2018) 165, A3326

HPR-40 DEMS

for Differential Electrochemical Mass Spectrometry

The Hiden HPR-40 DEMS is a benchtop or mobile cart mounted module for analysis of dissolved species in electrochemistry. The system is modular and adaptable. The system includes two differential electrochemical mass spectrometry 'DEMS' cell inlets, designed for material/catalysis studies (cell type A), and electrochemical reaction studies (cell type B).

For applications where Online Electrochemical MS (OEMS) from an existing cell or reactor is required a range of standard inlet options is available offering both evolved off-gas and dissolved species analysis solutions. The HPR-40 DEMS system has a mass range of 200 amu (300 amu option) and sub ppm detection levels.



HPR-40 DEMS system

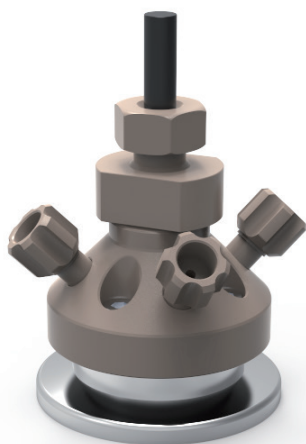

Cell type A

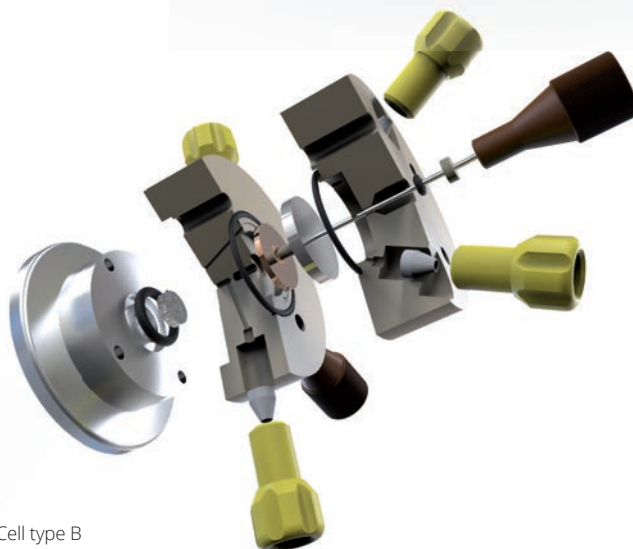

Cell type B

FEATURES:

- ▶ Compact benchtop mass spectrometer system
- ▶ Mass scanning, and time/intensity trend monitoring of multiple species
- ▶ Modular, user configurable system including DEMS cell
- ▶ Fast response (< 1 second), nano-porous electrolyte/MS interface
- ▶ DEMS off-gas analysis capillary sampling option with micro-flow inlet
- ▶ Mass range: 200 amu is standard. 300 amu option

HPR-60 MBMS

the Ultimate Solution for Reactive Gas & Plasma Analysis

The Hiden HPR-60 molecular beam mass spectrometer is a compact skimmer inlet MS for the analysis of reactive gas phase intermediates. Radicals are sampled via a multistage differentially pumped skimmer inlet and transferred to the MS ion source with minimal interaction with other species and without wall collisions. Customisable inlets allow connection to many different reactor systems, including atmospheric plasmas.

The skimmer system, combined with a Hiden triple filter precision mass spectrometer, offers a sampling system with ultra fast response and high accuracy.

- ▶ catalytic reactors
- ▶ reaction kinetics
- ▶ study of transients
- ▶ plasma chemistry

HPR-60 MBMS

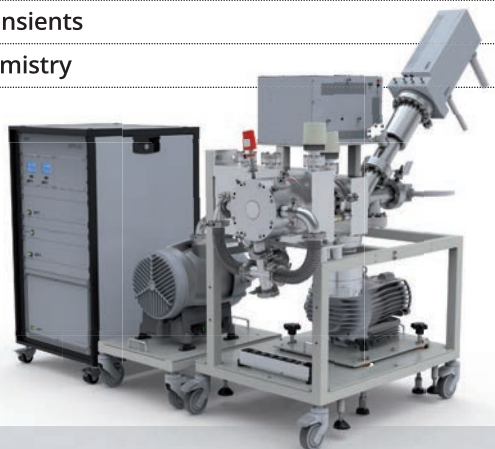

FEATURES:

- ▶ Positive and negative ion analysis
- ▶ Appearance potential spectra for radical analysis
- ▶ Electron attachment Mass Spectrometry (EAMS) mode option for electronegative radicals analysis
- ▶ Front stage heating option up to 1000°C
- ▶ Molecular beam chopper option for automated beam foreground-background measurement
- ▶ Windows® MASsoft Professional PC software with RS232, USB, and Ethernet communication links
- ▶ Enhanced pumping for sampling to 5 bar
- ▶ Options to configure integral MS for standalone studies in vacuum chamber
- ▶ MCS detector option for 50 ns time resolved sampling
- ▶ Liquid N2 cryopanel for parts-per-billion level studies

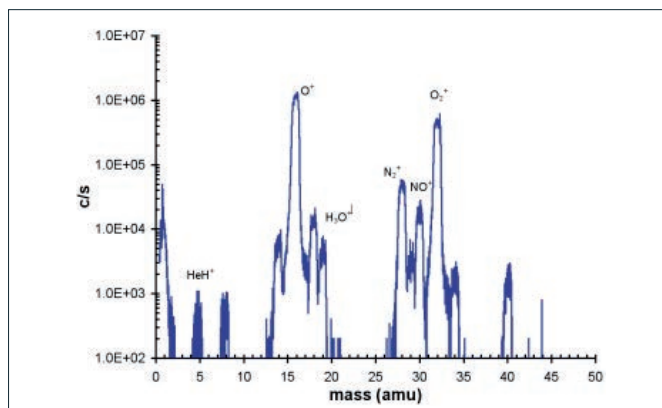

Positive ion mass spectrum from a typical atmospheric treatment device.

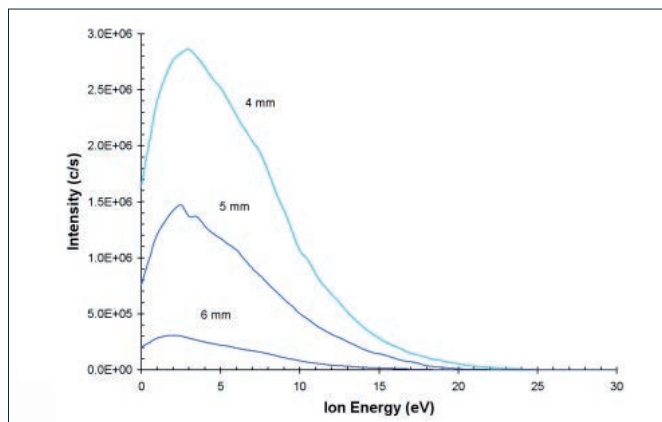

Nitrogen Ion Energy Distribution as a function of distance from an atmospheric plasma treatment device.

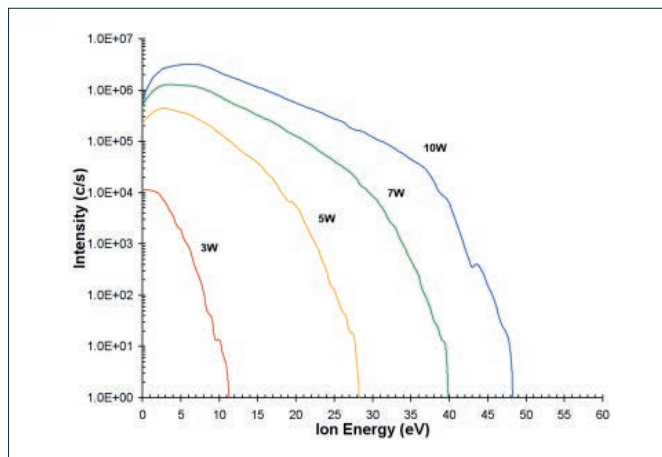

Oxygen ion energy as a function of plasma power from an atmospheric plasma treatment device

HPR-70

for Discrete Low Volume Sample Analysis

The Hiden HPR-70 compact benchtop batch inlet gas analysis system is suitable for the analysis of discrete gas samples.

A small quantity of gas, usually at or close to atmospheric pressure, is sampled using an automated batch inlet. After expansion and consequent pressure drop the gas is analysed using a high sensitivity 500 amu quadrupole mass spectrometer.

Most minor components in the gas mixture can be measured at ppm levels.

- ▶ landfill and environmental monitoring
- ▶ nuclear gas analysis
- ▶ head space measurements
- ▶ fuel cell analysis
- ▶ geological samples

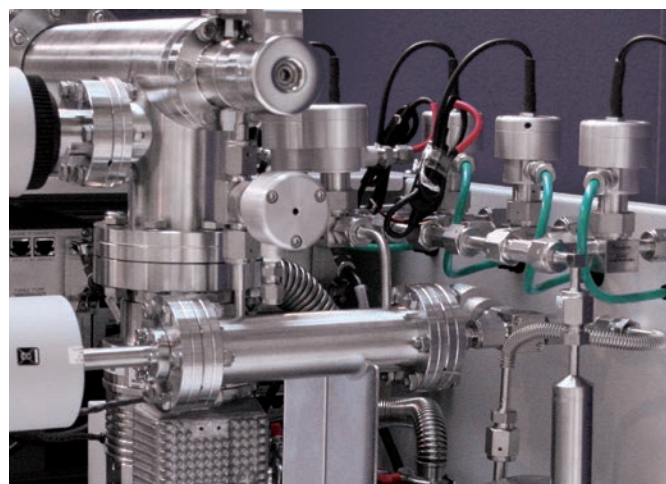

HPR-70 batch inlet

Parameters/Scans:	Argon 40	Hydrogen 2	Water 18	N2/CO 28	Oxygen 32	CO2 44	Ar % 0.4	H2_ppm 0.4	H2O_ppm 0.4	N2/CO_ppm 0.4	O2_ppm 0.4	CO2_ppm 0.4
Elapsed time	mbar	mbar	mbar	mbar	mbar	mbar						
00:12.341	2.357E-06	8.731E-09	2.311E-09	1.926E-09	4.196E-11	3.653E-10	9.972E+01	1.697E+03	1.317E+02	7.602E-02	1.340E+01	1.507E+02
00:23.478	3.888E-06	8.803E-09	2.077E-09	1.793E-09	4.131E-11	3.598E-10	9.984E+01	1.048E+03	1.988E+01	4.273E-02	7.962E+00	9.005E+01
00:34.615	3.857E-06	8.616E-09	2.110E-09	1.790E-09	4.074E-11	3.486E-10	9.984E+01	1.009E+03	2.857E+01	4.300E-02	7.882E+00	8.790E+01
00:45.745	3.826E-06	8.524E-09	2.031E-09	1.689E-09	4.094E-11	3.518E-10	9.985E+01	9.929E+02	8.113E+00	4.072E-02	7.998E+00	8.943E+01
00:56.863	3.812E-06	8.452E-09	2.105E-09	1.678E-09	4.081E-11	3.543E-10	9.985E+01	9.775E+02	2.750E+01	4.056E-02	7.992E+00	9.040E+01
01:08.003	3.808E-06	8.328E-09	2.045E-09	1.754E-09	4.082E-11	3.510E-10	9.985E+01	9.460E+02	1.185E+01	4.260E-02	8.002E+00	8.965E+01
01:19.122	3.810E-06	8.306E-09	1.989E-09	1.699E-09	4.042E-11	3.519E-10	9.986E+01	9.399E+02	-2.771E+00	4.114E-02	7.895E+00	8.986E+01
01:30.258	3.821E-06	8.176E-09	2.043E-09	1.764E-09	4.040E-11	3.494E-10	9.986E+01	9.032E+02	1.128E+01	4.274E-02	7.866E+00	8.893E+01

HPR-70 batch inlet sampling schematic

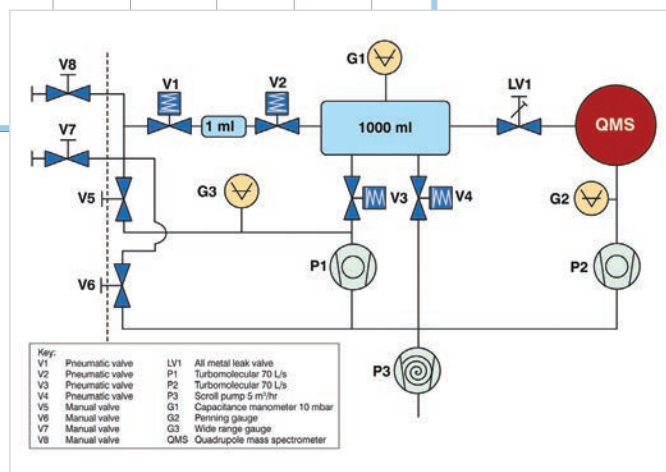

FEATURES:

- ▶ Dual compound turbo pumps and oil-free, totally dry backing pump
- ▶ Automatic dosing, expansion and accurate sampling
- ▶ Total sample pressure measurement with capacitance manometer
- ▶ Optional aliquot filling facility
- ▶ 1 litre sample reservoir
- ▶ 1 ml injection reservoir
- ▶ Optional calibration lines

LAS LEAK ANALYSIS SYSTEM

Automated Battery Leak Testing

Energy storage is increasingly important in modern life. As our reliance on battery powered devices increases, lifetime and performance are critical features of the technology. Battery failure rate and lifetime are dependent on contamination of the battery remaining at a minimum. Therefore battery leak tightness is vitally important to ensure that no electrolyte can escape from the sealed battery or other gases can enter the battery.

The Hiden Leak Analysis System is automated for simple use in quality control or R&D environments and is designed for analysing the leak tightness of small to medium size battery assemblies. The system can detect leak rates of less than 1×10^{-7} mbar.l/s with self-calibration checks against known leak rate standards.

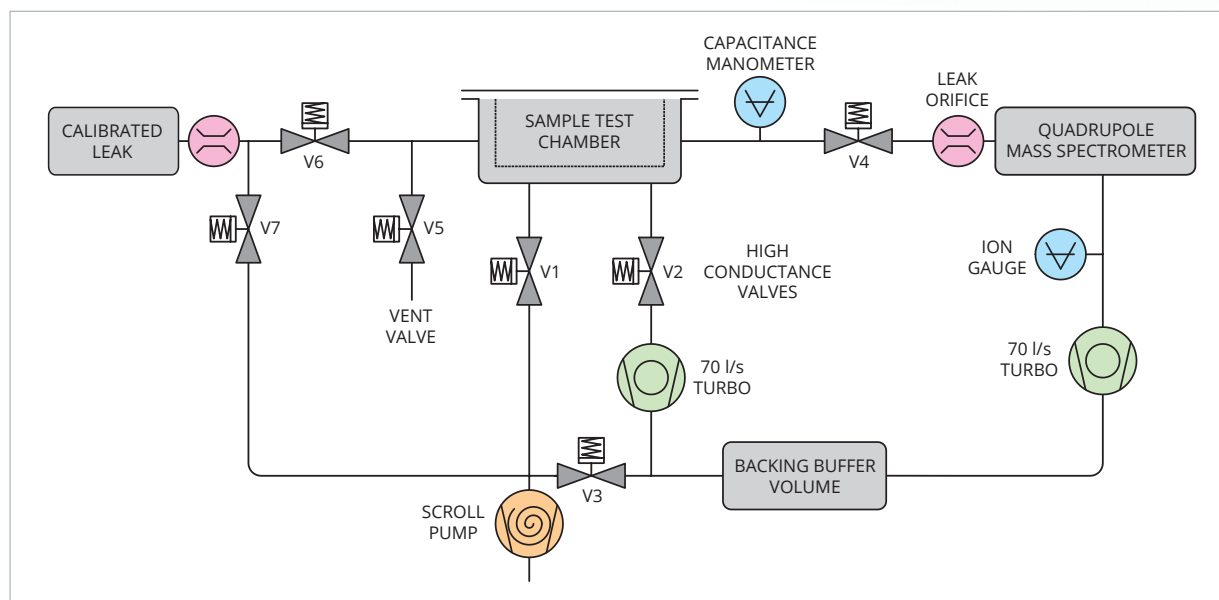

FEATURES:

- ▶ Automated operation
- ▶ High throughput
- ▶ Dry, contamination free testing method
- ▶ Highly sensitive
- ▶ Non-destructive testing



QGA 2 SOFTWARE

for Quantitative Gas and Vapour Analysis

QGA 2 software is an application specific software package for quantitative gas and vapour analysis providing real-time continuous analysis of up to 32 species with species concentration measured in the range 0.1 ppm to 100%. The software can be used in either single stream or multistream mode with gas selection valves up to 80 streams.

The software features easy-to-use calibration routines for both cracking pattern and Relative Sensitivity (RS) measurement. Analysis is performed using simple template setup routines and features automatic spectral removal algorithms and correction factor determination to output quantitative data. Integrated inputs from external devices such as CO-analyser make the software versatile for a whole range of gas analysis applications.

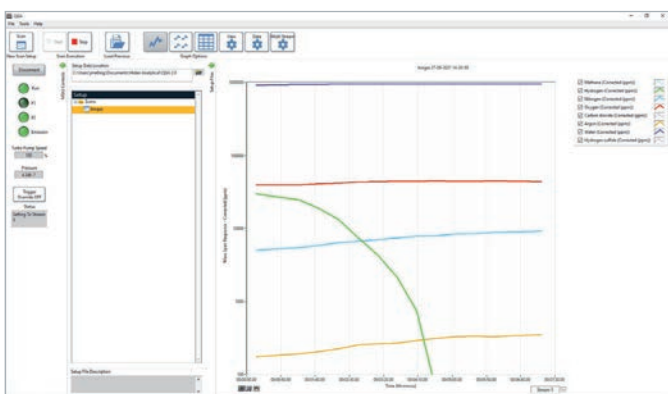

QGA 2 home screen

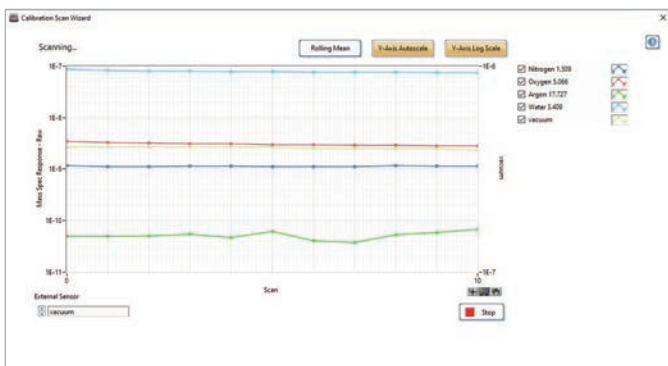

QGA 2 calibration

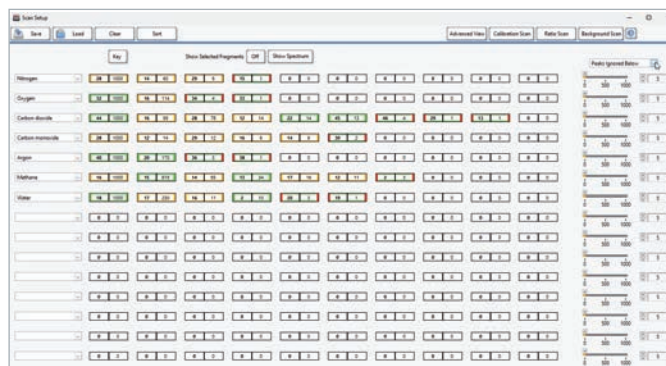

QGA 2 automatic mass spectral analysis setup

FEATURES:

- ▶ Quantitative gas analysis of up to 32 gases
- ▶ 10 peak spectral library with intelligent library scan feature
- ▶ Component gas calibration with background correction
- ▶ Automatic triggering of analysis from an external input
- ▶ Read multiple inputs, temperature or pressure for example
- ▶ X-axis can display time or an external input, e.g. temperature

EGAsoft SOFTWARE for Evolved Gas Analysis

Hidden EGAsoft for evolved gas analysis data acquisition and analysis. Designed to simplify evolved gas analysis from devices such as thermogravimetric analysers (TGA), the software minimises the number of settings that are required, making it easy to use for even novice users. The 3D graphing of bar scan data ensures that trends can be easily identified from the decomposition of unknown substances while the Multiple Ion Detection (MID) mode allows desorption trends over time/temperature to be displayed.

Hidden collaborates with a range of TGA manufacturers to ensure the compatibility of the file export functions with their software. Unknowns can also be identified using the NIST export function.

In addition to the acquisition features the software also features some post process analysis functions such as peak integration and peak deconvolution with multiple Gaussian peaks. Data smoothing and anomalous data point removal features are also available.

- ▶ TGA-MS
- ▶ Temperature Programmed Desorption (TPD)
- ▶ Thermal Decomposition

FEATURES:

- ▶ 3D bar scan view for easy determination of trends in bar data
- ▶ Simple automatic export in formats specific for import to any TGA/STA manufacturer's software
- ▶ Automatic spectral deconvolution in MID mode
- ▶ Peak integration and data analysis routines
- ▶ Auto-sequencing of MS data acquisition files e.g. for use with auto samplers
- ▶ Auto start/stop and temperature inputs where output signals are available
- ▶ Mass spectrometer ionisation energy control for soft ionisation of complex mixtures

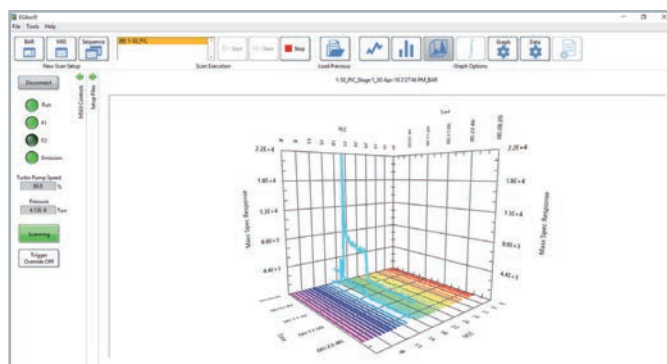

EGAsoft 3D bar mode

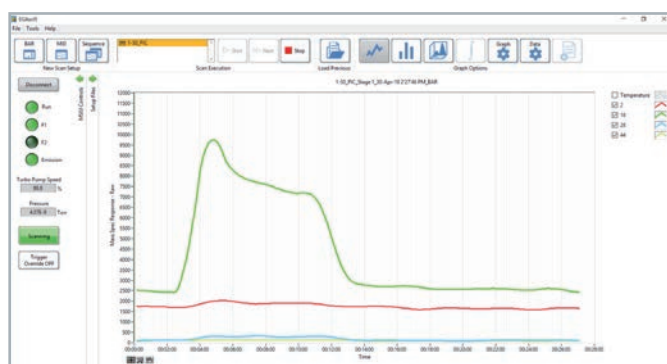

EGAsoft MID view

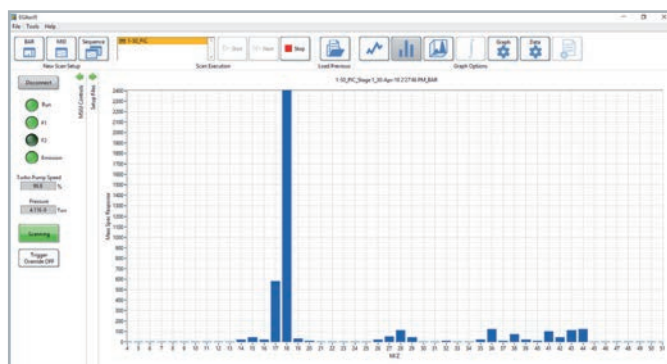

EGAsoft 2D bar mode

MASsoft PROFESSIONAL Control Software

All Hiden instruments are supplied with MASsoft Professional mass spectrometer control software. MASsoft Professional is a multilevel software package allowing both simple control of mass spectrometer parameters and complex manipulation of data and control of external devices.

Quick start tabs with user configurable single key start functions means novice users can start collecting data within seconds.

Scan templates allow fast set up of scans from previous similar experiments.

User selected alarm facilities (including status indication with message send and output drive capability) provide powerful control for process environments.

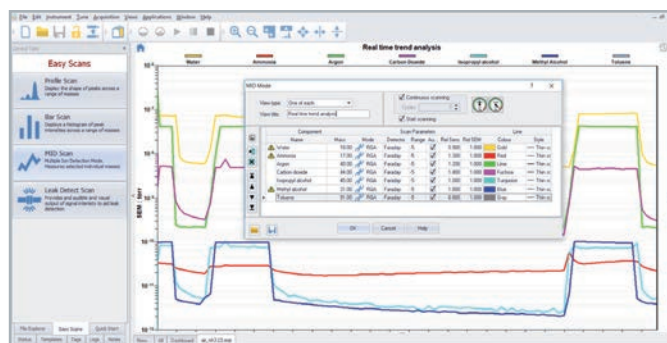

MASsoft PROFESSIONAL trend analysis (MID) setup

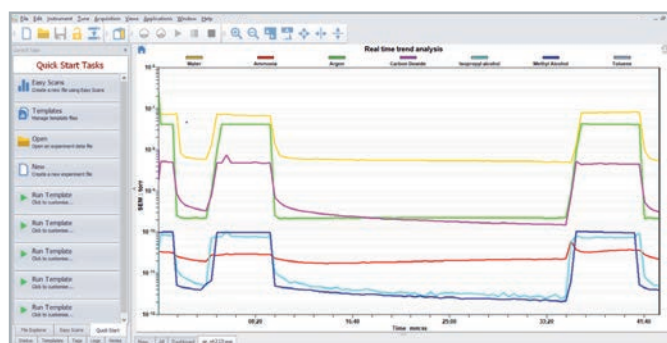

MASsoft PROFESSIONAL scan gallery



MASsoft PROFESSIONAL overview

FEATURES:

- ▶ Mass spectrometer ionisation energy control for soft ionisation of complex mixtures
- ▶ Export data to NIST MS database for analysis of unknowns
- ▶ Export to external data analysis software, e.g. Excel, Origin
- ▶ Control of external devices, e.g. MFCs, gas switching/sampling valves and furnace PID controllers
- ▶ Output data as percentage or ppm files
- ▶ Real-time subtraction of overlapping peaks



JEVINSTRUMENTS.COM

Hidden **APPLICATIONS**

Hidden's quadrupole mass spectrometer systems address a broad application range in:

GAS ANALYSIS

- ▶ Dynamic measurement of reaction gas streams
- ▶ Catalysis and thermal analysis
- ▶ Molecular beam studies
- ▶ Dissolved species probes
- ▶ Fermentation, environmental and ecological studies



SURFACE ANALYSIS

- ▶ UHV TPD/TDS
- ▶ ToF qSIMS and SIMS analysers
- ▶ End point detection in ion beam etch
- ▶ Elemental imaging – 3D mapping
- ▶ SIMS system with simultaneous dual polarity analysis

PLASMA DIAGNOSTICS

- ▶ Plasma source characterisation
- ▶ Etch and deposition process reaction kinetic studies
- ▶ Analysis of neutral and radical species

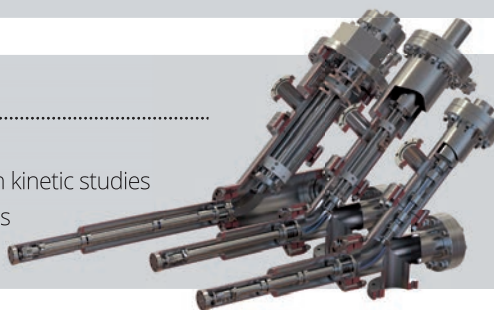

VACUUM ANALYSIS

- ▶ Partial pressure measurement and control of process gases
- ▶ Reactive sputter process control
- ▶ Vacuum diagnostics
- ▶ Vacuum coating process monitoring



HIDEN

ANALYTICAL

Hidden Analytical Ltd.
420 Europa Boulevard
Warrington WA5 7UN England

T +44 [0] 1925 445 225

E info@hidden.co.uk

W www.HiddenAnalytical.com



Sales Offices:

We have sales offices situated around the globe. **Visit our website for further information.**